

DESCRIPTION: MALE - CRIMP AND LOAD

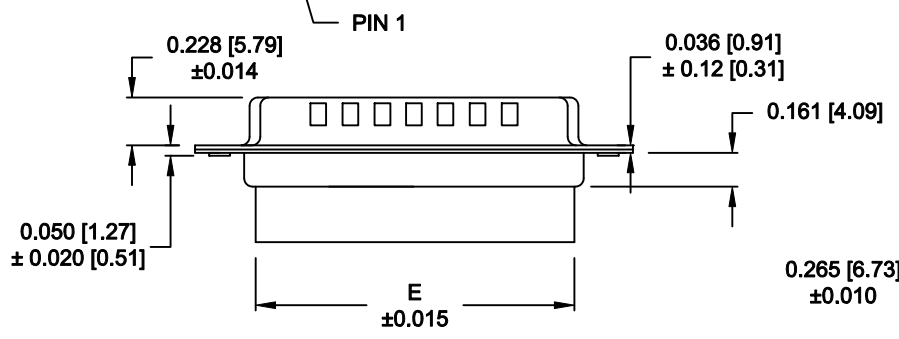
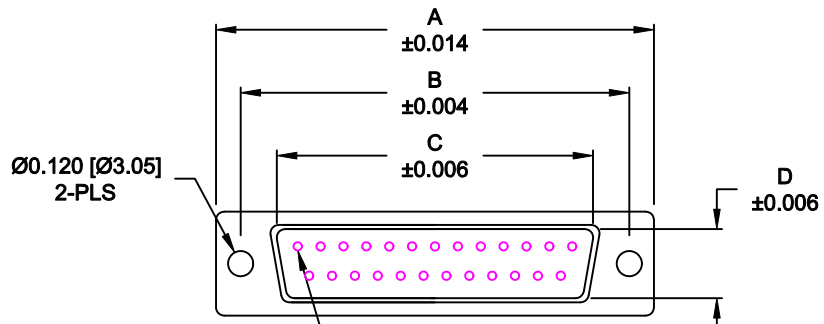

No. OF PINS	DIMENSIONS						
	A	B	C	D	E	F	G
9	1.213	0.984	0.669	0.331	0.618	0.496	0.429
	30.80	24.99	17.00	8.40	15.70	12.60	10.90
15	1.541	1.312	0.996	0.331	0.933	0.496	0.429
	39.15	33.32	25.30	8.40	23.70	12.60	10.90
25	2.088	1.852	1.535	0.331	1.496	0.496	0.429
	53.04	47.04	39.00	8.40	38.00	12.60	10.90
37	2.729	2.500	2.181	0.331	2.142	0.496	0.429
	69.32	63.50	55.40	8.40	54.40	12.60	10.90
50	2.635	2.406	2.079	0.437	2.039	0.602	0.535
	66.93	61.11	52.80	11.10	51.80	15.30	13.60

**MATERIAL:**

SHELL: STEEL, TIN OR NICKEL PLATED  
 INSULATOR: UL 94V-O RATED, PBT +30% FIBER-GLASS

**ELECTRICAL:**

CURRENT RATING: 5 AMPS  
 CONTACT RESISTANCE: 15 mOhms Max.  
 INSULATION RESISTANCE: 1,000 MOhms min.  
 VOLTAGE: 500VAC FOR 1 MINUTE  
 TEMPERATURE: -50° C TO 125° C

**RoHS COMPLIANT**

**170-YYY-17YL000**

SERIES \_\_\_\_\_  
 POSITIONS \_\_\_\_\_  
 009 \_\_\_\_\_  
 015 \_\_\_\_\_  
 025 \_\_\_\_\_  
 037 \_\_\_\_\_  
 050 \_\_\_\_\_  
 GENDER \_\_\_\_\_  
 1 = MALE  
 TERMINATION \_\_\_\_\_  
 7 = CRIMP & LOAD  
 SHELL PLATING \_\_\_\_\_  
 2 = TIN  
 3 = NICKEL (GROUND INDENTS)  
 RoHS COMPLIANT \_\_\_\_\_  
 HARDWARE OPTIONS \_\_\_\_\_  
 00 = NO HARDWARE  
 01 = .098" CLINCH NUT (BOARD SIDE)  
 02 = .236" CLINCH NUT (BOARD SIDE)  
 03 = .236" CLINCH NUT (MATING SIDE)  
 PLATING OPTIONS \_\_\_\_\_  
 0 = NO CONTACTS

DO NOT SCALE FROM DRAWING

	THESE DRAWINGS AND SPECIFICATIONS ARE THE PROPERTY OF NorComp AND SHALL NOT BE REPRODUCED, COPIED OR USED AS THE BASIS FOR THE MANUFACTURE OF SALE OF APPARATUS WITHOUT WRITTEN PERMISSION.		DRAWN: <b>PAM JENKINS</b>	DATE: <b>8-18-98</b>
			CHECKED:	DATE:
<b>NorComp</b>		SCALE: <b>1 : 1</b>	SHEET <b>1</b> OF <b>2</b>	REV <b>9</b>
		DWG NO. <b>170-YYY-17YL000</b>		

**ALL CLINCH-NUTS ARE 4-40 INTERNAL THREADS**

01X ..... 0.065" (BOARD SIDE) - CN1

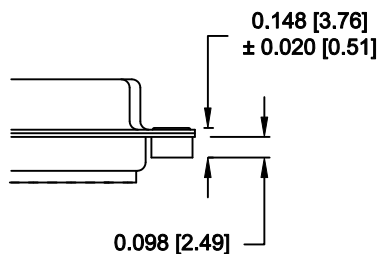

02X ..... 0.236" (BOARD SIDE) - CN2

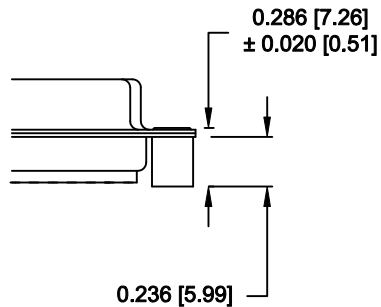

03X..... 0.236" (MATING SIDE) - CN8

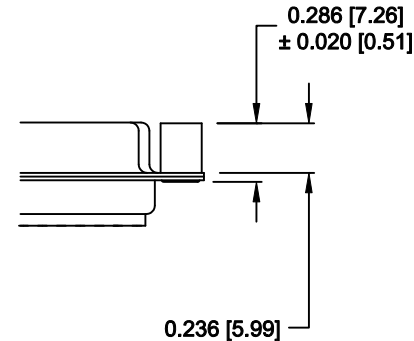

**DO NOT SCALE FROM DRAWING**

	THESE DRAWINGS AND SPECIFICATIONS ARE THE PROPERTY OF NorComp AND SHALL NOT BE REPRODUCED, COPIED OR USED AS THE BASIS FOR THE MANUFACTURE OF SALE OF APPARATUS WITHOUT WRITTEN PERMISSION.		DRAWN: <b>C. SMITH</b>	DATE: <b>03-08-06</b>
			CHECKED:	DATE:
<h1>NorComp</h1>		SCALE: <b>FULL</b>	SHEET <b>2</b> OF <b>2</b>	REV <b>9</b>
		DWG NO. <b>170-YYY-17YL000</b>		

**RoHS COMPLIANT**