

DESCRIPTION: MALE - DIP SOLDER - HIGH PROFILE

No. OF PINS	DIMENSIONS						
	A	B	C	D	E	F	G
9	1.213	0.984	0.669	0.331	0.618	0.496	0.429
	30.80	24.99	17.00	8.40	15.70	12.60	10.90
15	1.541	1.312	0.996	0.331	0.933	0.496	0.429
	39.15	33.32	25.30	8.40	23.70	12.60	10.90
25	2.088	1.852	1.535	0.331	1.496	0.496	0.429
	53.04	47.04	39.00	8.40	38.00	12.60	10.90
37	2.729	2.500	2.181	0.331	2.142	0.496	0.429
	69.32	63.50	55.40	8.40	54.40	12.60	10.90
50	2.635	2.406	2.079	0.437	2.039	0.602	0.535
	66.93	61.11	52.80	11.10	51.80	15.30	13.60

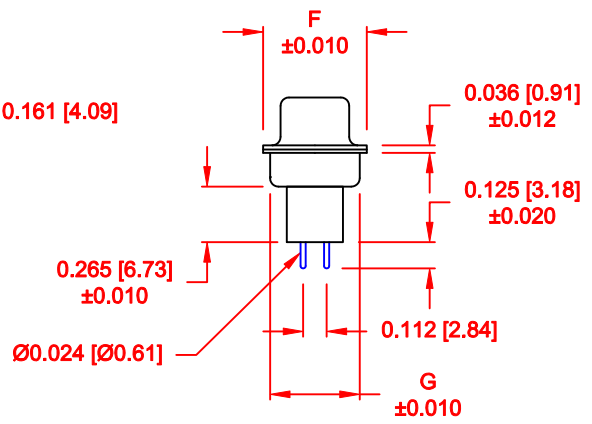
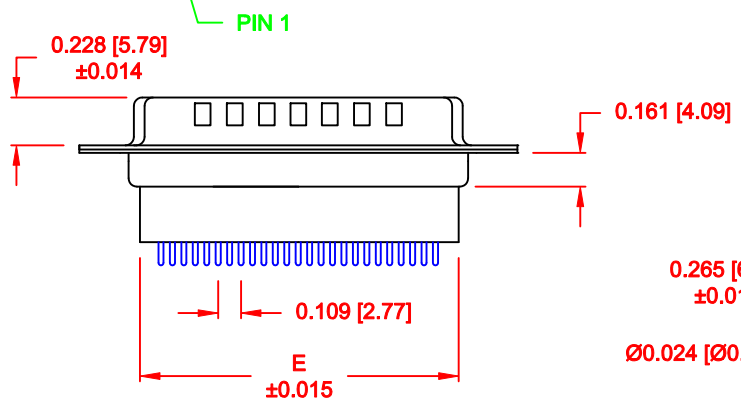
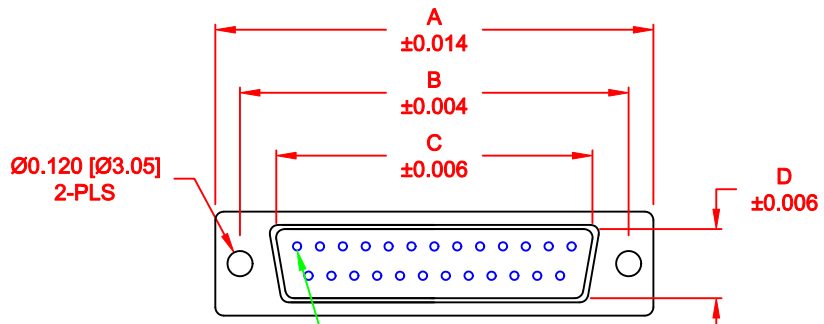

172-YYY-18YLYY1

SERIES _____
 POSITIONS _____
 009 _____
 015 _____
 025 _____
 037 _____
 050 _____
 GENDER _____
 1 = MALE _____
 TERMINATION _____
 8 = HIGH PROFILE VERTICAL _____
 SHELL PLATING _____
 3 = NICKEL (GROUND INDENTS) _____
 RoHS COMPLIANT _____
 HARDWARE OPTIONS _____
 00 = NO HARDWARE _____
 01 = .098" CLINCH NUT (BOARD SIDE) _____
 02 = .236" CLINCH NUT (BOARD SIDE) _____
 03 = .236" CLINCH NUT (MATING SIDE) _____
 PLATING OPTIONS _____
 1 = GOLD FLASH _____
 2 = 30u" GOLD _____

MATERIAL:

SHELL: STEEL, NICKEL PLATED
 INSULATOR: UL 94V-O RATED, PBT
 +30% FIBER-GLASS OR NYLON-66

ELECTRICAL:

CURRENT RATING: 5 AMPS
 CONTACT RESISTANCE: 15 mOhms Max.
 INSULATION RESISTANCE: 1,000 MOhms min.
 VOLTAGE: 500VAC FOR 1 MINUTE
 TEMPERATURE: -50° C TO 125° C

DO NOT SCALE FROM DRAWING

RoHS COMPLIANT

	THESE DRAWINGS AND SPECIFICATIONS ARE THE PROPERTY OF NorComp AND SHALL NOT BE REPRODUCED, COPIED OR USED AS THE BASIS FOR THE MANUFACTURE OF SALE OF APPARATUS WITHOUT WRITTEN PERMISSION.	DRAWN: WAYNE ROBBINS CHECKED:	DATE: 08-23-98 DATE:
	<h1>NorComp</h1>	SCALE: 1:1 DWG NO. 172-YYY-18YLYY1	SHEET 1 OF 3

DESCRIPTION: PCB LAYOUT - STANDARD "D" - MALE & FEMALE

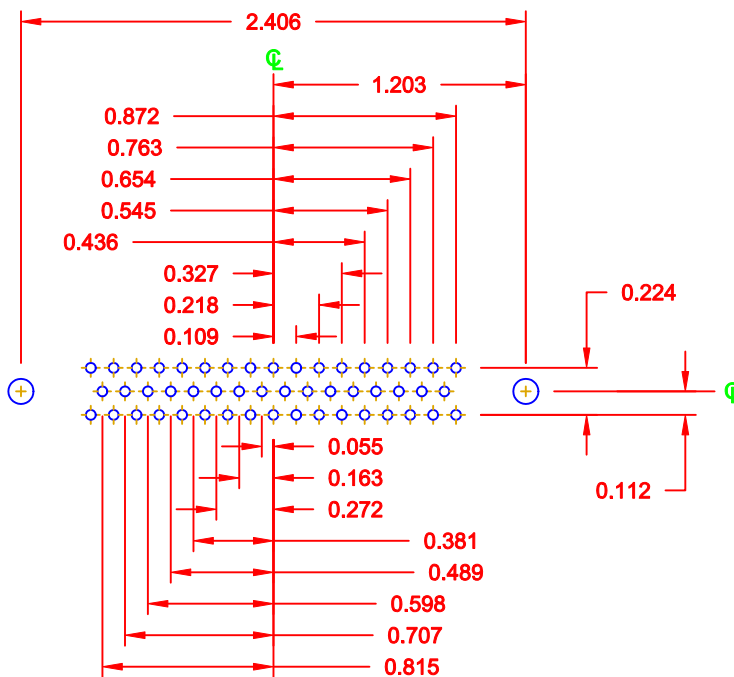
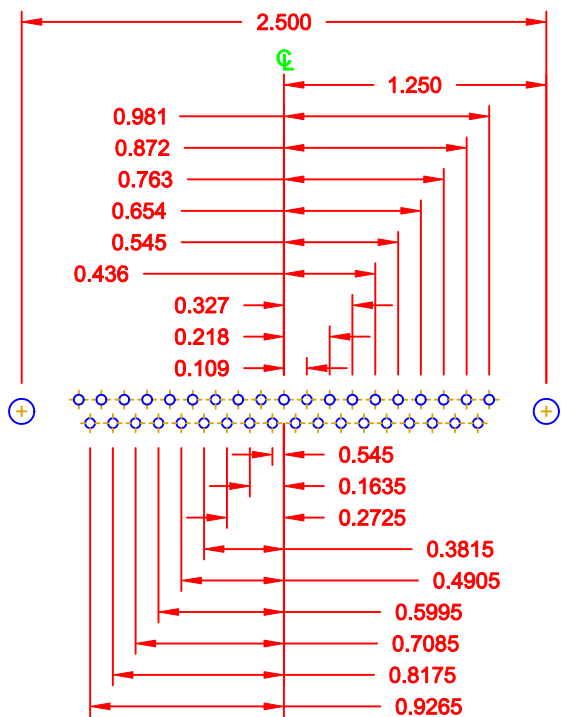
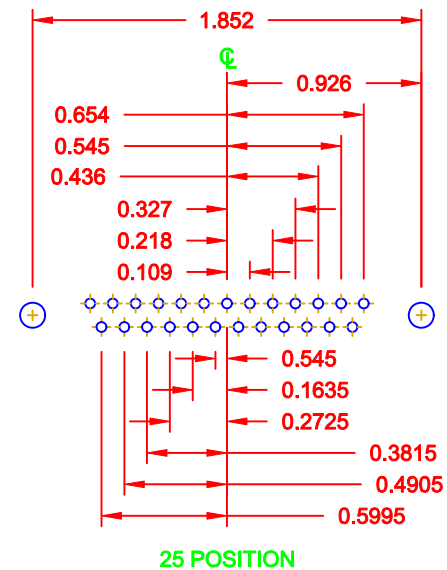
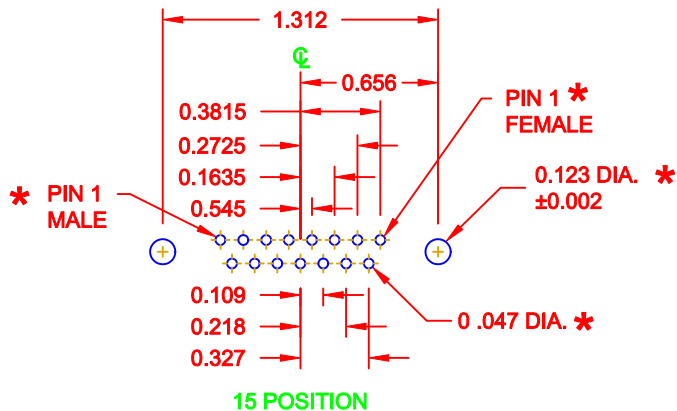
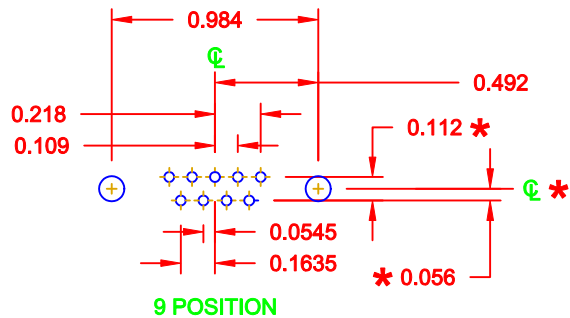

* TYP. ON ALL SIZES

DO NOT SCALE FROM DRAWING

	THESE DRAWINGS AND SPECIFICATIONS ARE THE PROPERTY OF NorComp AND SHALL NOT BE REPRODUCED, COPIED OR USED AS THE BASIS FOR THE MANUFACTURE OF SALE OF APPARATUS WITHOUT WRITTEN PERMISSION.		DRAWN: C. SMITH	DATE: 03-08-06
			CHECKED:	DATE:
NorComp	SCALE: FULL	SHEET 2 OF 3	REV 15	
	DWG NO. 172-YYY-18YLYY1			

TOLERANCE:
ALL DIMENSIONS ARE ± 0.010

ALL CLINCH-NUTS ARE 4-40 INTERNAL THREADS

01X 0.065" (BOARD SIDE) - CN1

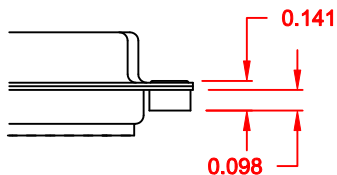

02X 0.236" (BOARD SIDE) - CN2

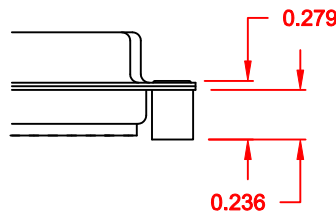

03X..... 0.236" (MATING SIDE) - CN8

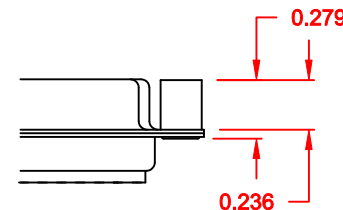

DO NOT SCALE FROM DRAWING

RoHS COMPLIANT

	THESE DRAWINGS AND SPECIFICATIONS ARE THE PROPERTY OF NorComp AND SHALL NOT BE REPRODUCED, COPIED OR USED AS THE BASIS FOR THE MANUFACTURE OF SALE OF APPARATUS WITHOUT WRITTEN PERMISSION.		DRAWN: WAYNE ROBBINS	DATE: 11-28-05	
			CHECKED:	DATE:	
<h1>NorComp</h1>			SCALE:	SHEET 3 OF 3	REV 15
			DWG NO. 172-YYY-18YLYY1		