

NOTE: INSULATOR DESIGN CHANGE

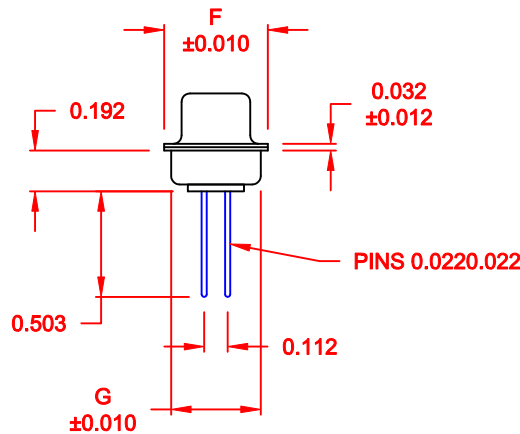
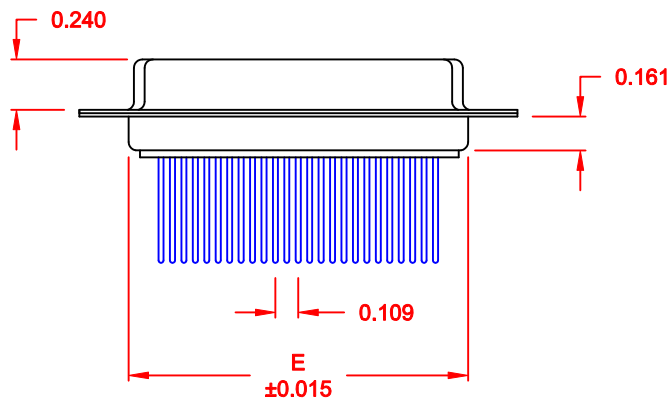
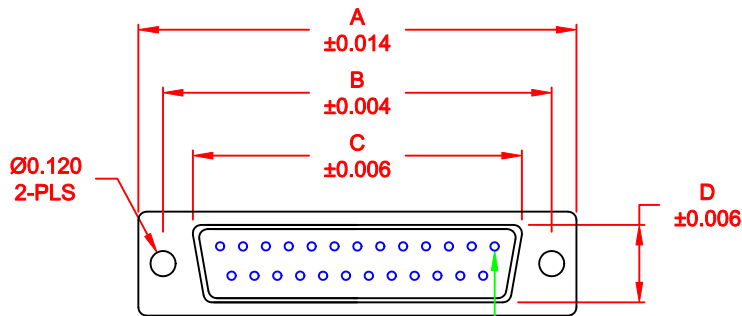

MATERIAL:

SHELL: STEEL, TIN
 INSULATOR: UL 94V-O RATED, BEIGE PBTP
 PROCESS TEMP.: 260° C
 CONTACT: BRASS

ELECTRICAL:

CURRENT RATING: 5 AMPS
 CONTACT RESISTANCE: 15 mOhms Max.
 INSULATION RESISTANCE: 1,000 MOhms min.
 VOLTAGE: 500VAC FOR 1 MINUTE
 TEMPERATURE: -50° C TO 100° C



RoHS COMPLIANT

No. OF PINS	DIMENSIONS						
	A	B	C	D	E	F	G
9	1.213	0.984	0.642	0.315	0.760	0.496	0.429
	30.80	24.99	16.30	8.00	19.30	12.60	10.90
15	1.541	1.312	0.969	0.315	1.083	0.496	0.429
	39.15	33.32	24.60	8.00	27.51	12.60	10.90
25	2.088	1.852	1.512	0.315	1.630	0.496	0.429
	53.04	47.04	38.40	8.00	41.40	12.60	10.90
37	2.729	2.500	2.157	0.315	2.276	0.496	0.429
	69.32	63.50	54.80	8.00	57.81	12.60	10.90
50	2.635	2.406	2.059	0.425	2.182	0.598	0.535
	66.93	61.11	52.30	10.80	55.42	15.20	13.60

172-YYY-242RYY1

SERIES _____
 POSITIONS _____
 009 _____
 015 _____
 025 _____
 037 _____
 050 _____
 GENDER _____
 2 = FEMALE
 TERMINATION _____
 4 = WIRE WRAP
 SHELL PLATING _____
 2 = TIN
 RoHS COMPLIANT _____
 HARDWARE OPTIONS _____
 00 = NO HARDWARE
 01 = .065" CLINCH NUT (BOARD SIDE)
 02 = .250" CLINCH NUT (BOARD SIDE)
 03 = .250" CLINCH NUT (MOUNTING SIDE)
 05 = .237" 4-40 BOARD LOCK
 91 = .237" 4-40 SPACER/ BOARD LOCK
 PLATING OPTIONS _____
 1 = GOLD FLASH
 2 = 30MICRO-INCH GOLD

DO NOT SCALE FROM DRAWING

	THESE DRAWINGS AND SPECIFICATIONS ARE THE PROPERTY OF NorComp AND SHALL NOT BE REPRODUCED, COPIED OR USED AS THE BASIS FOR THE MANUFACTURE OF SALE OF APPARATUS WITHOUT WRITTEN PERMISSION.	DRAWN: PAM JENKINS CHECKED:	DATE: 09-12-05 DATE:
		SCALE: 1:1 DWG NO. 172-YYY-242RYY1	SHEET 1 OF 2 REV 9

ALL CLINCH-NUTS ARE 4-40 INTERNAL THREADS

01X 0.065" (BOARD SIDE) - CN1

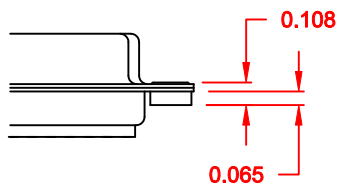

05X 0.237" (BOARD SIDE) - CN10

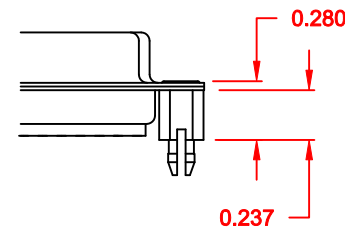

02X 0.250" (BOARD SIDE) - CN2

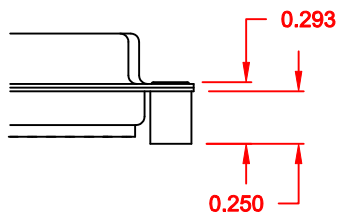

91X 0.237" (BOARD SIDE) - 0.197" MATING SIDE - CN10/SFSO4404

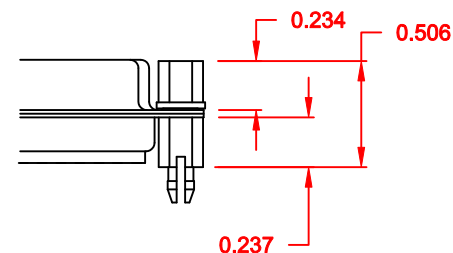

03X..... 0.250" (MATING SIDE) - CN8

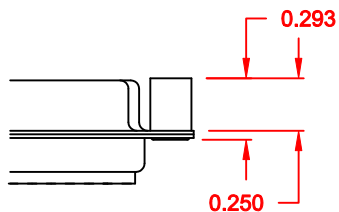

NOTE: 4-40 FEMALE SCREW LOCK IS REMOVABLE

DO NOT SCALE FROM DRAWING

RoHS COMPLIANT

	THESE DRAWINGS AND SPECIFICATIONS ARE THE PROPERTY OF NorComp AND SHALL NOT BE REPRODUCED, COPIED OR USED AS THE BASIS FOR THE MANUFACTURE OF SALE OF APPARATUS WITHOUT WRITTEN PERMISSION.		DRAWN: WAYNE ROBBINS	DATE: 11-28-05
			CHECKED:	DATE:
<h1>NorComp</h1>		SCALE:	SHEET 2 OF 2	REV 9
		DWG NO. 172-YYY-242RYY1		