

DESCRIPTION: FEMALE - 0.370 RIGHT ANGLE / MACHINED - ECONOMY

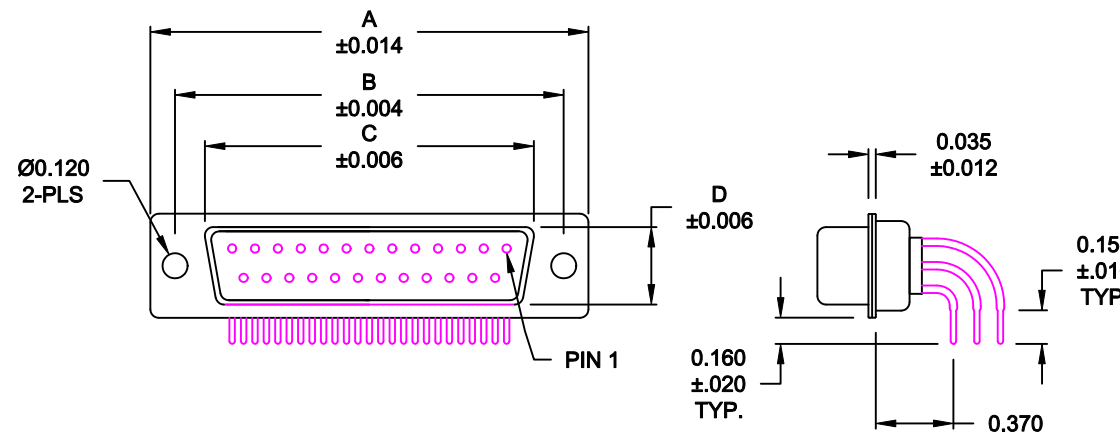

No. OF PINS	DIMENSIONS							
	A	B	C	D	E	F	G	H
9	1.213	0.984	0.642	0.311	0.236	0.756	0.496	0.427
	30.80	24.99	16.30	7.90	5.99	19.20	12.60	10.85
15	1.541	1.312	0.970	0.311	0.236	1.091	0.496	0.427
	39.15	33.32	24.65	7.90	5.99	27.70	12.60	10.85
25	2.087	1.852	1.512	0.311	0.236	1.618	0.496	0.427
	53.00	47.04	38.40	7.90	5.99	41.10	12.60	10.85
37	2.728	2.500	2.157	0.311	0.236	2.256	0.496	0.427
	69.30	63.50	54.80	7.90	5.99	57.30	12.60	10.85
50	2.638	2.406	2.055	0.429	0.240	2.169	0.602	0.527
	67.00	61.11	52.20	10.90	6.10	55.10	15.30	13.39

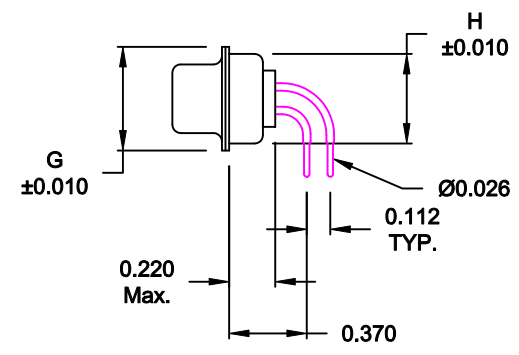
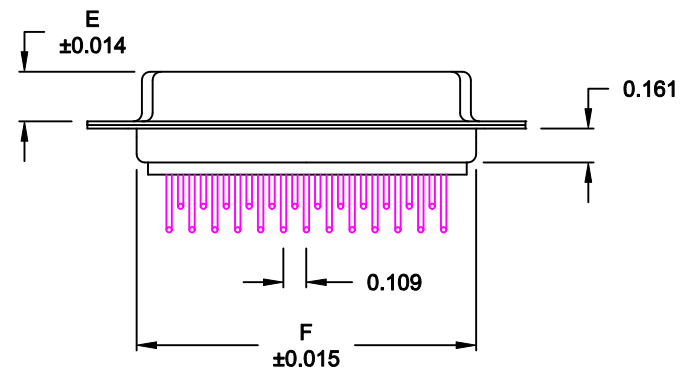

174-EYY-21YRYY1

- SERIES _____
- POSITIONS _____
- E09 _____
- E15 _____
- E25 _____
- E37 _____
- E50 _____
- GENDER _____
- 2 = FEMALE
- TERMINATION _____
- 1 = PC MOUNTING
- SHELL PLATING _____
- 3 = NICKEL
- RoHS COMPLIANT _____
- HARDWARE OPTIONS _____
- 00 = NO HARDWARE
- 14 = SHORT BRACKET WITH 4-40 SCREW LOCK
- 24 = SHORT BRACKET WITH 4-40 SCREW
- PLATING OPTIONS _____
- 1 = GOLD FLASH
- 2 = 30MICRO-INCH GOLD
- 3 = 50MICRO-INCH GOLD

MATERIAL:

- SHELL: STEEL, NICKEL PLATED
- INSULATOR: UL 94V-O RATED, WHITE PA6T
- PROCESS TEMP.: 260° PROCESS TEMPERATURE
- CONTACT: BRASS

ELECTRICAL:

- CURRENT RATING: 5 AMPS
- CONTACT RESISTANCE: 15 mOhms Max.
- INSULATION RESISTANCE: 1,000 MOhms min.
- VOLTAGE: 500VAC FOR 1 MINUTE
- TEMPERATURE: -50° C TO 100° C

DO NOT SCALE FROM DRAWING

	THESE DRAWINGS AND SPECIFICATIONS ARE THE PROPERTY OF NorComp AND SHALL NOT BE REPRODUCED, COPIED OR USED AS THE BASIS FOR THE MANUFACTURE OF SALE OF APPARATUS WITHOUT WRITTEN PERMISSION.		DRAWN: WAYNE ROBBINS	DATE: 11-28-05
			CHECKED:	DATE:
NorComp		SCALE: 1:1	SHEET 1 OF 3	REV 7
		DWG NO. 174-EYY-21YRYY1		

RoHS COMPLIANT

DESCRIPTION: PCB LAYOUT - STANDARD "D" - MALE & FEMALE

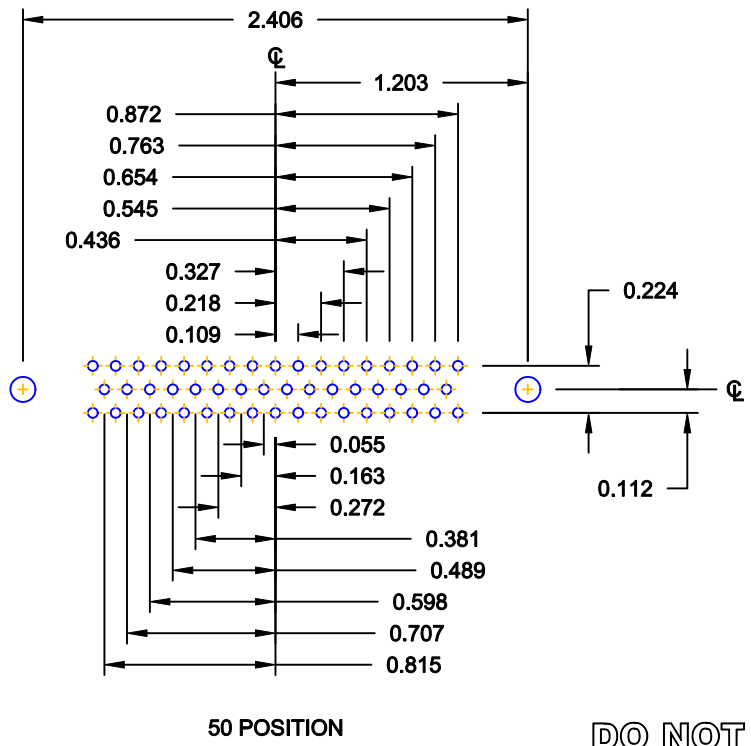
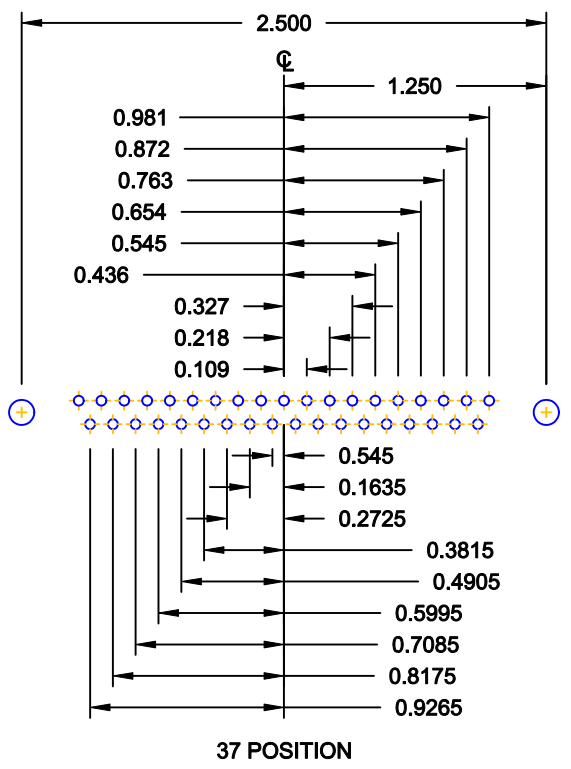
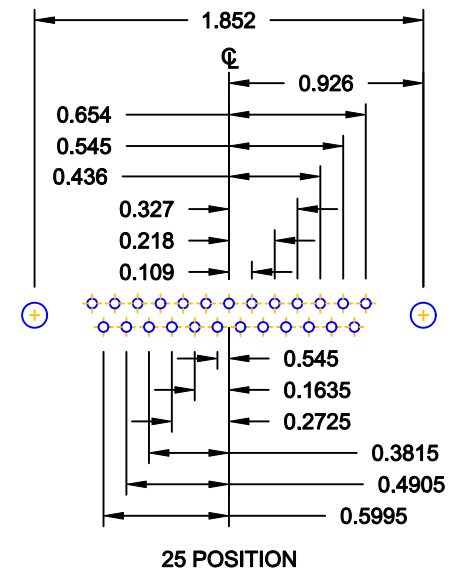
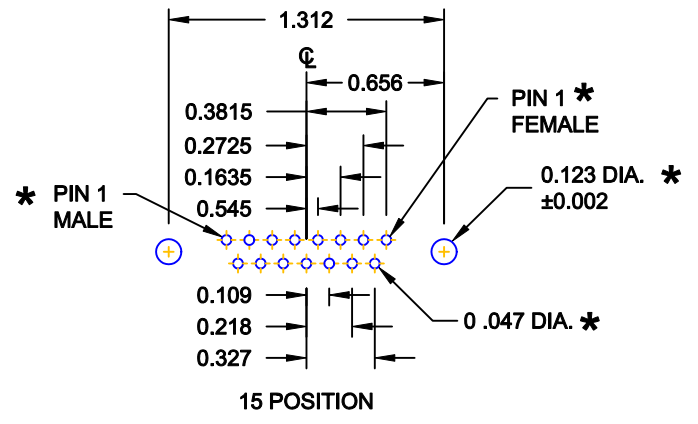
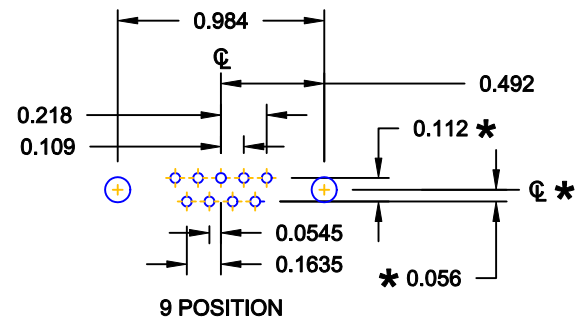

* TYP. ON ALL SIZES

DO NOT SCALE FROM DRAWING

	THESE DRAWINGS AND SPECIFICATIONS ARE THE PROPERTY OF NorComp AND SHALL NOT BE REPRODUCED, COPIED OR USED AS THE BASIS FOR THE MANUFACTURE OF SALE OF APPARATUS WITHOUT WRITTEN PERMISSION.		DRAWN: C. SMITH	DATE: 03-08-06
			CHECKED:	DATE:
NorComp	SCALE: FULL	SHEET 2 OF 3	REV 7	
	DWG NO. 174-EYY-21YRY1			

HARDWARE OPTIONS

REPLACE -YY IN LAST 3 DIGITS WITH OPTION CHOSEN

173/174 SERIES

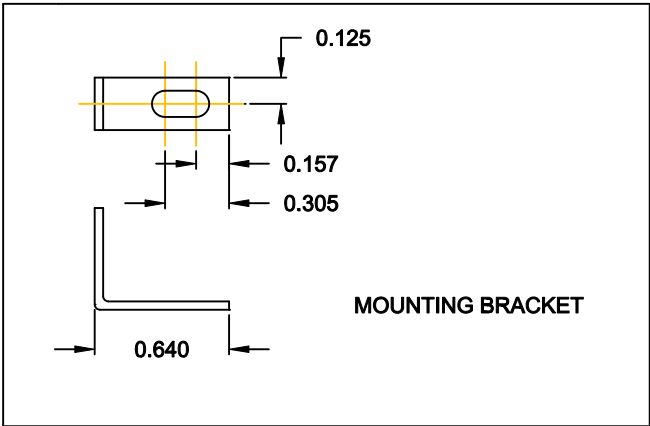

173 / 174 SERIES

- 14Y = SHORT BRACKET & 4-40 FEMALE HEX SOCKET
- 24Y = SHORT BRACKET & 4-40 SCREW

175/176 SERIES

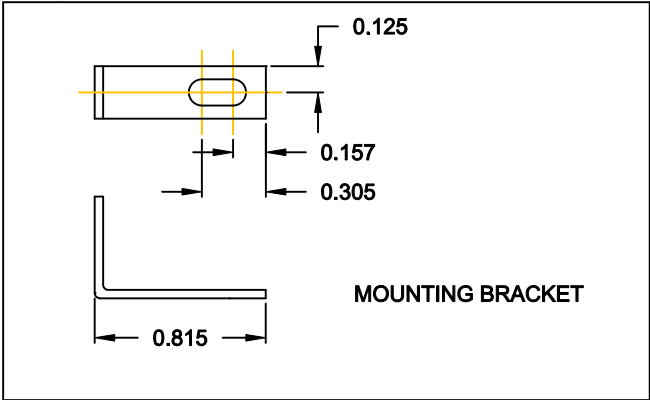

175 / 176 SERIES

- 15Y = LONG BRACKET & 4-40 FEMALE HEX SOCKET
- 25Y = SHORT BRACKET & 4-40 SCREW

MATERIAL: COLD ROLLED STEEL
 PLATING: CLEAR ZINC

RoHS COMPLIANT

DO NOT SCALE FROM DRAWING

	THESE DRAWINGS AND SPECIFICATIONS ARE THE PROPERTY OF NorComp AND SHALL NOT BE REPRODUCED, COPIED OR USED AS THE BASIS FOR THE MANUFACTURE OF SALE OF APPARATUS WITHOUT WRITTEN PERMISSION.		DRAWN: PAM JENKINS	DATE: 11-28-05	
			CHECKED:	DATE:	
<h1>NorComp</h1>			SCALE: 1:1	SHEET 3 OF 3	REV 7
			DWG NO. 174-EYY-21YRYY1		