

DESCRIPTION: HIGH DENSITY - MACHINED CONTACTS - RIGHT ANGLE

MATERIALS AND FINISH:

SHELL: STEEL MATERIAL, NICKEL FINISH
 INSULATOR: PA6T=260°C, UL 94V-0 RATED, BLACK
 CONTACT MATERIAL: BRASS
 CONTACT FINISH: SELECTIVE GOLD FINISHED

ELECTRICAL:

CONTACT CURRENT RATING: 5 AMPS
 CONTACT RESISTANCE: 30 Milliohms Max.
 DIELECTRIC WITHSTANDING VOLTAGE: 1,000VAC Min.
 INSULATION RESISTANCE: 5,000 Megohms Min.
 TEMPERATURE RATING: -55° ~ +105° C

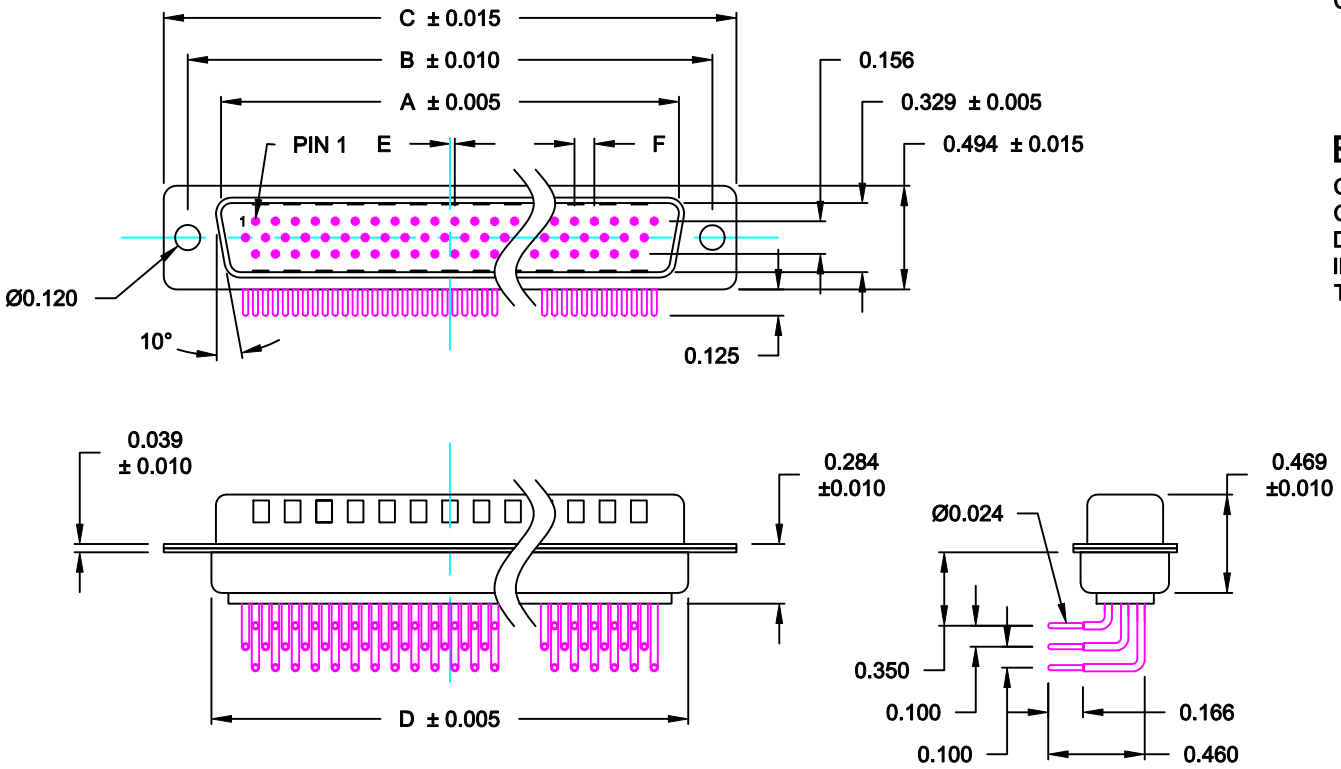

181-MYY-1YYRYYY

SERIES _____
 MACHINED CONTACTS _____
 POSITIONS _____
 15 _____
 26 _____
 44 _____
 62 _____
 GENDER _____
 1 = MALE _____
 TERMINATION _____
 1 = RIGHT ANGLE _____
 SHELL PLATING _____
 3 = NICKEL _____
 RoHS COMPLIANT _____
 HARDWARE OPTIONS _____
 14 = BRACKET WITH #4-40 INSERT, BOARD LOCK AND LOCATOR PLATE _____
 PLATING OPTIONS _____
 1 = GOLD FLASH, ENTIRE CONTACT _____
 2 = 30u" GOLD, ENTIRE CONTACT _____

DIMENSIONS (IN.)

No. OF PINS	A	B	C	D	E	F
15	0.666	0.984	1.213	0.759	0.010	0.090
25	0.994	1.312	1.541	1.083	0.020	0.090
44	1.534	1.852	2.088	1.625	0.020	0.090
62	2.182	2.500	2.729	2.272	0.023	0.095

DO NOT SCALE FROM DRAWING

	THESE DRAWINGS AND SPECIFICATIONS ARE THE PROPERTY OF NorComp AND SHALL NOT BE REPRODUCED, COPIED OR USED AS THE BASIS FOR THE MANUFACTURE OF SALE OF APPARATUS WITHOUT WRITTEN PERMISSION.		DRAWN: C. SMITH	DATE: 03-16-07
			CHECKED:	DATE:
NorComp	SCALE: 1 : 1	SHEET 1	OF 4	REV 9
	DWG NO. 181-MYY-1YYRYYY			

RoHS COMPLIANT

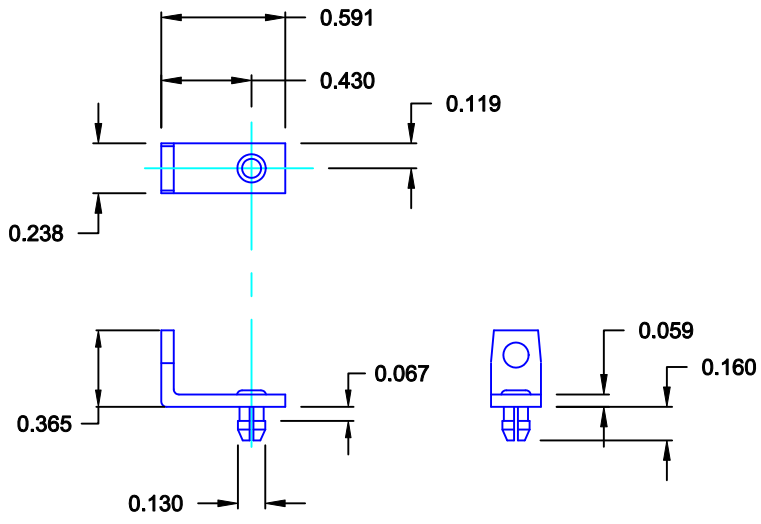

MOUNTING BRACKET WITH BOARD LOCK

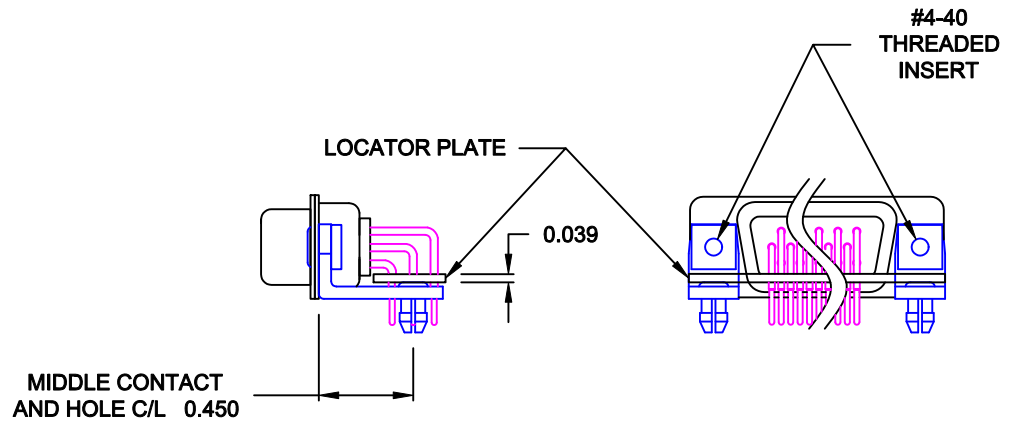

BRACKETS MOUNTED ON CONNECTOR WITH LOCATOR PLATE

FOR CLARITY
HIDDEN LINES
NOT SHOWN

MATERIAL: COLD ROLLED STEEL
PLATING: CLEAR ZINC

	THESE DRAWINGS AND SPECIFICATIONS ARE THE PROPERTY OF NorComp AND SHALL NOT BE REPRODUCED, COPIED OR USED AS THE BASIS FOR THE MANUFACTURE OF SALE OF APPARATUS WITHOUT WRITTEN PERMISSION.		DRAWN: PAM JENKINS	DATE: 11-28-05	
	<h1>NorComp</h1>			CHECKED:	DATE:
SCALE: 1 : 1				SHEET 2 OF 4	REV 9
DWG NO. 181-MYY-1YYRYYY					

NOTE: MALE LOCATOR PLATE SHOWN
FLIP FOR FEMALE

MATERIAL: INSULATION PAPER
0.039" THICK

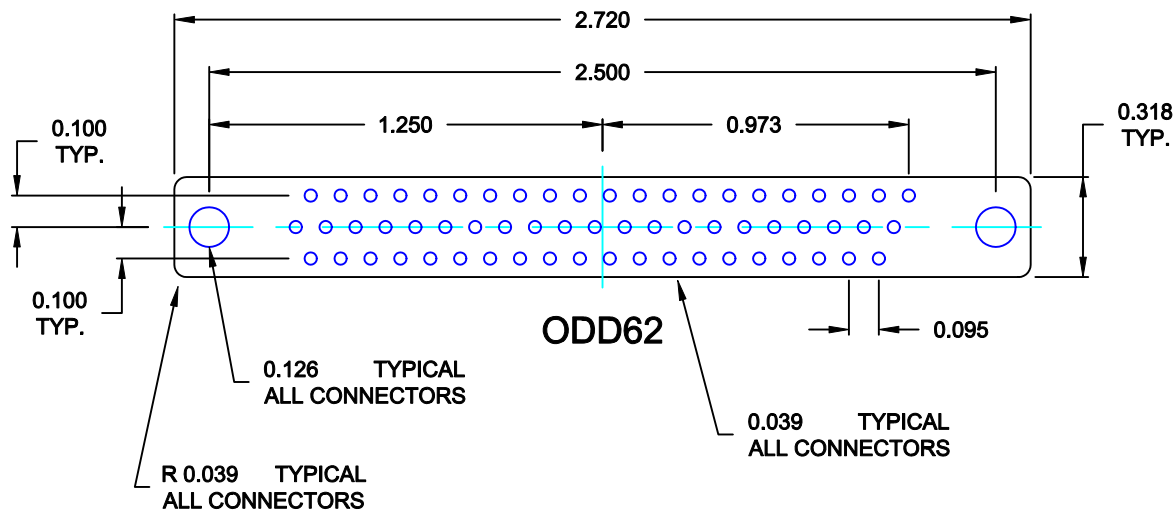
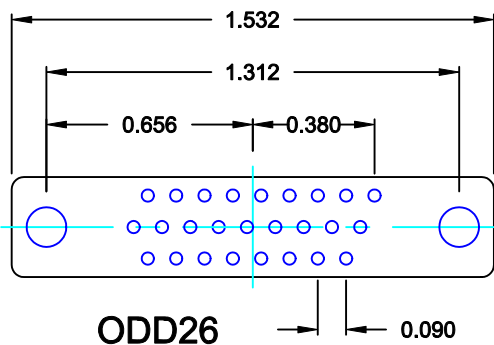
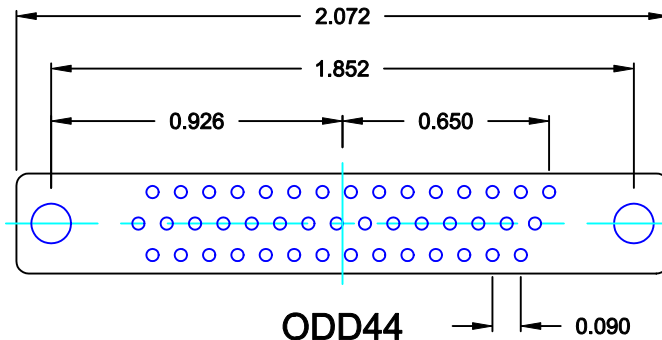
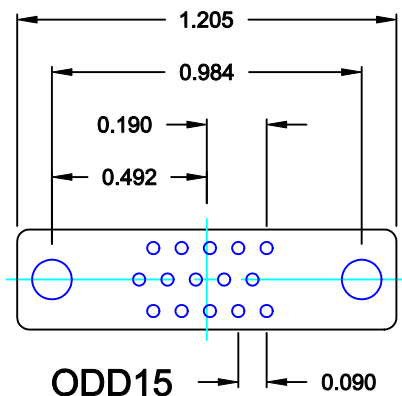

DO NOT SCALE FROM DRAWING

	THESE DRAWINGS AND SPECIFICATIONS ARE THE PROPERTY OF NorComp AND SHALL NOT BE REPRODUCED, COPIED OR USED AS THE BASIS FOR THE MANUFACTURE OF SALE OF APPARATUS WITHOUT WRITTEN PERMISSION.		DRAWN: C. SMITH	DATE: 02-18-08
			CHECKED:	DATE:
<h1>NorComp</h1>		SCALE: 1.5 : 1	SHEET 3 OF 4	REV 9
		DWG NO. 181-MYY-1YYRYYY		

RoHS COMPLIANT

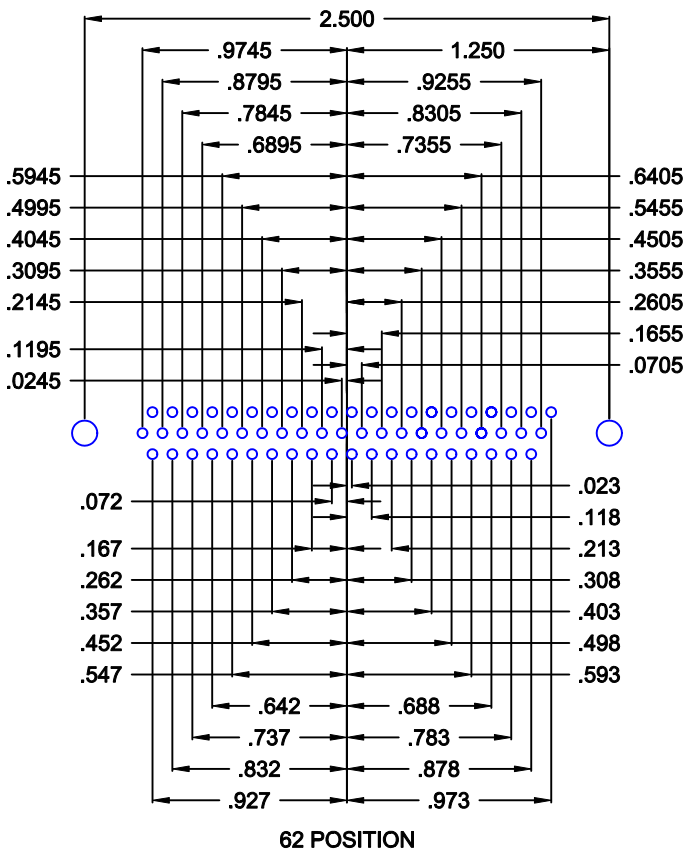
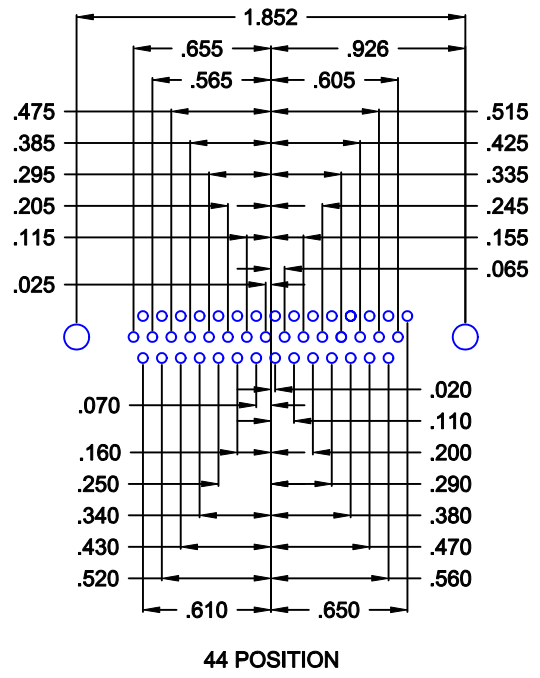
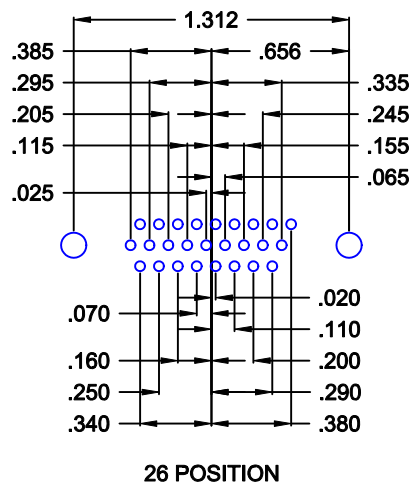
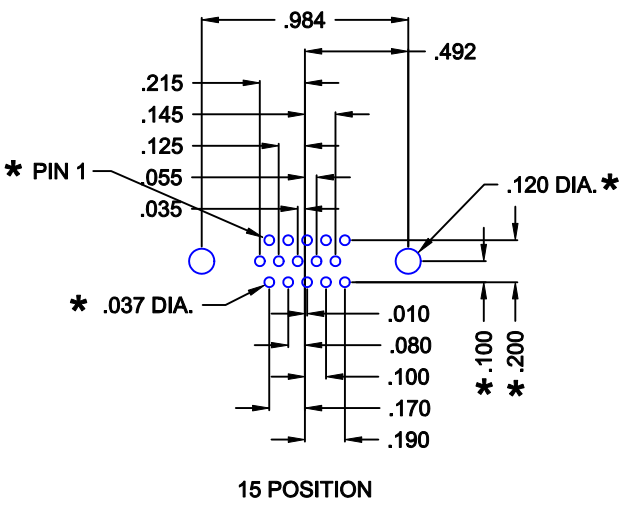

* TYP. ON ALL SIZES

DO NOT SCALE FROM DRAWING

	THESE DRAWINGS AND SPECIFICATIONS ARE THE PROPERTY OF NorComp AND SHALL NOT BE REPRODUCED, COPIED OR USED AS THE BASIS FOR THE MANUFACTURE OF SALE OF APPARATUS WITHOUT WRITTEN PERMISSION.		DRAWN: C. SMITH	DATE: 03-16-07
			CHECKED:	DATE:
NorComp		SCALE: 1 : 1	SHEET 4 OF 4	REV 9
		DWG NO. 181-MYY-1YYRYYY		