

DESCRIPTION: VERTICAL MOUNT MALE LOW PROFILE/PLASTIC BACK PRESS FIT

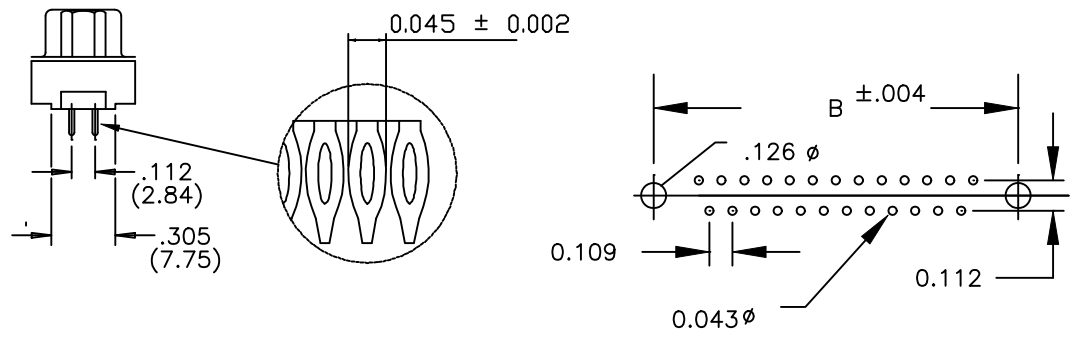
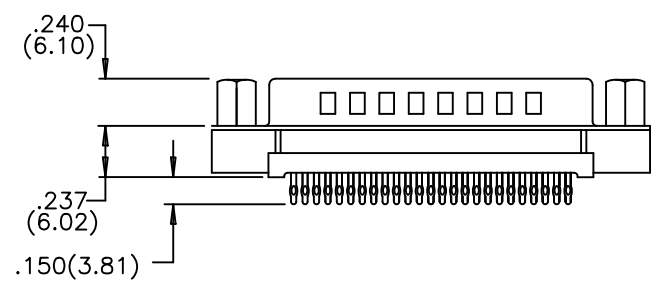
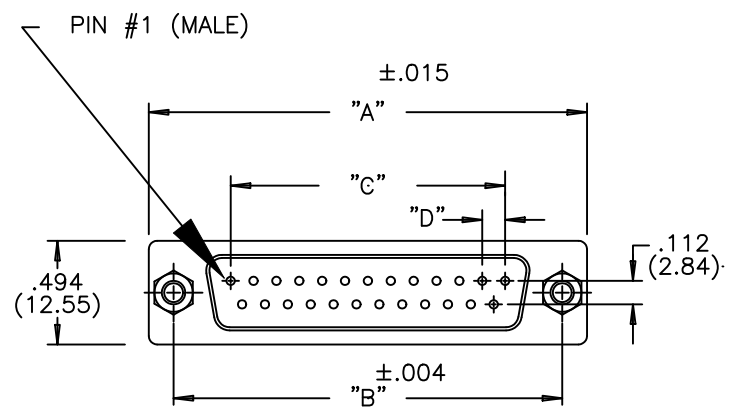

(9, 15, 25, 37 POSITIONS)

NUMBER OF CONTACTS	"A" Inch (mm)	"B" Inch (mm)	"C" Inch (mm)	"D" Inch (mm)
9	1.214 (30.84)	.984 (24.99)	.432 (10.97)	.109 (2.76)
15	1.545 (39.24)	1.312 (33.32)	.756 (19.20)	.109 (2.76)
25	2.088 (53.04)	1.852 (47.04)	1.304 (33.12)	.109 (2.76)
37	2.730 (69.34)	2.500 (63.50)	1.956 (49.68)	.109 (2.76)

MATERIALS:

INSULATOR: NYLON 6T, UL 94 V-0 260 °C PROCESS TEMP
CHEMICAL RESISTANCE, COLOR BLACK

SHELL: STEEL, NICKEL PLATED

CONTACT: MALE=BRASS; FEMALE=PHOSPHOR BRONZE
GOLD FLASH OR 30 MICRO-INCH IN MATING AREA
TIN PLATING ON TAIL ENDS

RoHS COMPLIANT

ELECTRICAL:

CURRENT RATING: 5 AMPERES
DIELECTRIC WITHSTANDING VOLTAGE: 1000VAC rms AT SEA LEVEL
INSULATION RESISTANCE: 5000 MEGOHMS MIN.
CONTACT RESISTANCE: 10 MILLIOHMS MAX.
WORKING TEMPERATURE: -55° TO +125° C

191-025-123RYYY

SERIES _____

NUMBER OF CONTACTS _____

GENDER _____

1 = MALE
2 = FEMALE (NO GROUND INDENTS)

TERMINATION _____

2 - PRESS FIT

SHELL _____

3 = NICKEL

HARDWARE OPTIONS: _____

00 = .125 HOLE
55 = 4-40 INSERT
56 = 4-40 INSERT WITH BOARD LOCKS
57 = 4-40 STANDOFF WITH BOARD LOCKS
59 = 4-40 STANDOFF

PLATING _____

1 = GOLD FLASH
2 = 30 MICRO-INCH GOLD



THESE DRAWINGS AND SPECIFICATIONS ARE THE PROPERTY OF NorComp AND SHALL NOT BE REPRODUCED, COPIED OR USED AS THE BASIS FOR THE MANUFACTURE OF SALE OF APPARATUS WITHOUT WRITTEN PERMISSION.

DRAWN: PAM JENKINS
DATE: 9-15-05

CHECKED: _____
DATE: _____

NorComp

SCALE: _____ SHEET 1 OF 2 REV 2

DWG NO. 191-YYY-123RYYY

00 = .125 DIA. HOLE

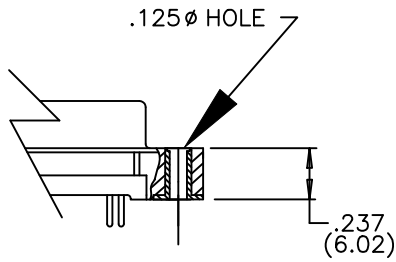

55 = 4-40 INSERT

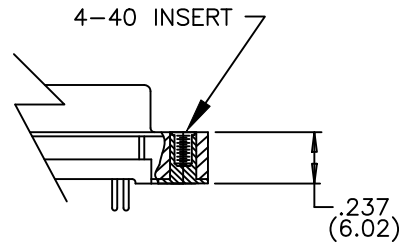

56 = 4-40 INSERT WITH BOARD LOCK

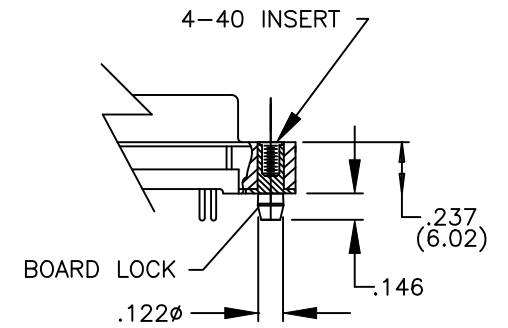

57 = 4-40 STANDOFF WITH BOARD LOCKS

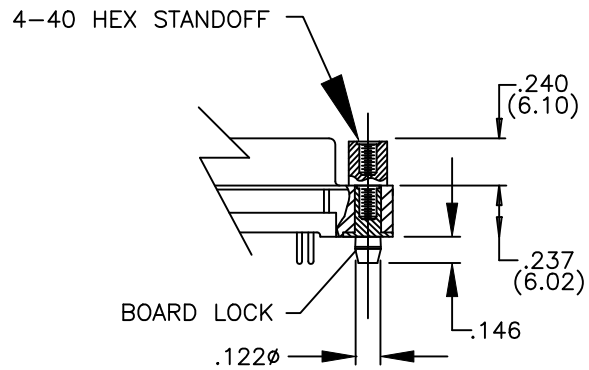

59 = 4-40 STANDOFF

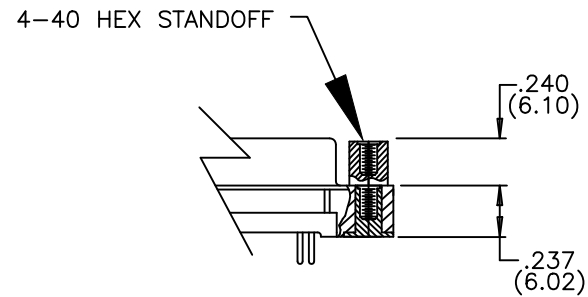

THESE DRAWINGS AND SPECIFICATIONS ARE THE PROPERTY OF NorComp AND SHALL NOT BE REPRODUCED, COPIED OR USED AS THE BASIS FOR THE MANUFACTURE OR SALE OF APPARATUS WITHOUT WRITTEN PERMISSION.

DRAWN:
PAM JENKINS

DATE:
9-15-03

CHECKED:

DATE:

NorComp

SCALE:

SHEET

OF

REV

2

2

2

DWG NO.

191 SERIES HARDWARE OPTIONS