

DESCRIPTION: HIGH DENSITY VERTICAL HIGH PROFILE MACHINED

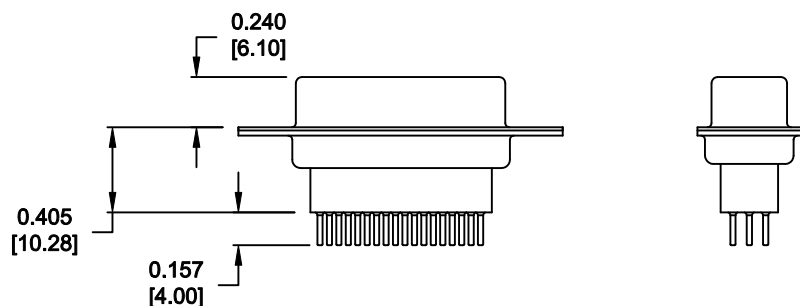
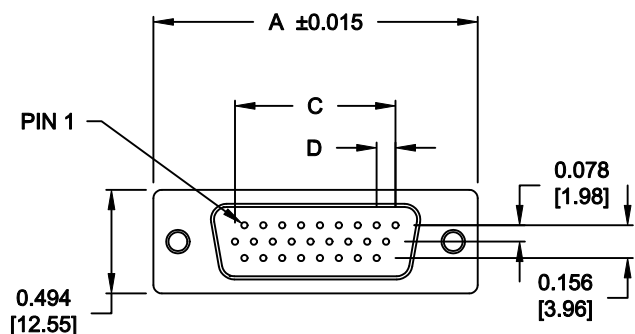

MATERIAL:

INSULATOR: PBT, UL94V-0, 230°C PROCESS TEMP.,
 CHEMICAL RESISTANCE, COLOR - BLACK
 SHELL: STEEL, NICKEL PLATED
 CONTACT: PHOSPHOR BRONZE, GOLD FLASH
 ENTIRE CONTACT

ELECTRICAL:

CURRENT RATING: 2 AMPS
 DIELECTRIC WITHSTANDING VOLTAGE: 1,000VAC rms
 INSULATION RESISTANCE: 5,000 MegOhms Min.
 CONTACT RESISTANCE: 10 MilliOhms Max.
 WORKING TEMPERATURE: -55°C TO +125°C

196-YYY-213LYY1

SERIES _____
 POSITIONS _____
 015 _____
 026 _____
 GENDER _____
 2 = FEMALE _____
 TERMINATION _____
 1 = PC MOUNT _____
 SHELL PLATING _____
 3 = NICKEL PLATED _____
 RoHS COMPLIANT (LOW TEMP. PROCESS) _____
 HARDWARE OPTIONS _____
 00 = 0.120" MOUNTING HOLE _____
 03 = 4-40 HEX STANDOFFS _____
 55 = 4-40 INSERTS _____
 PLATING _____
 1 = GOLD FLASH _____

No. OF PINS	DIMENSIONS (IN.)			
	A	B	C	D
15	1.214 [30.84]	0.984 [24.99]	0.405 [10.29]	0.090 [2.29]
26	1.545 [39.24]	1.312 [33.32]	0.765 [19.43]	0.090 [2.29]

DO NOT SCALE FROM DRAWING



THESE DRAWINGS AND SPECIFICATIONS ARE THE PROPERTY OF NorComp AND SHALL NOT BE REPRODUCED, COPIED OR USED AS THE BASIS FOR THE MANUFACTURE OF SALE OF APPARATUS WITHOUT WRITTEN PERMISSION.

DRAWN: PAM JENKINS

DATE: 09-15-05

CHECKED:

DATE:

NorComp

SCALE: 1:1 SHEET 1 OF 3 REV 5

DWG NO. 196-YYY-213-LYY1

RoHS COMPLIANT

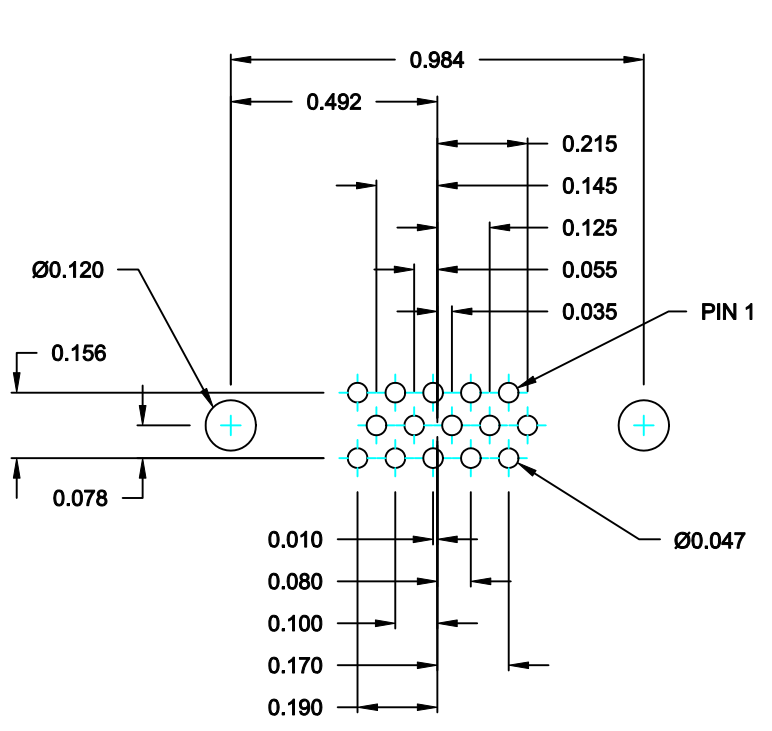

15 POSITION

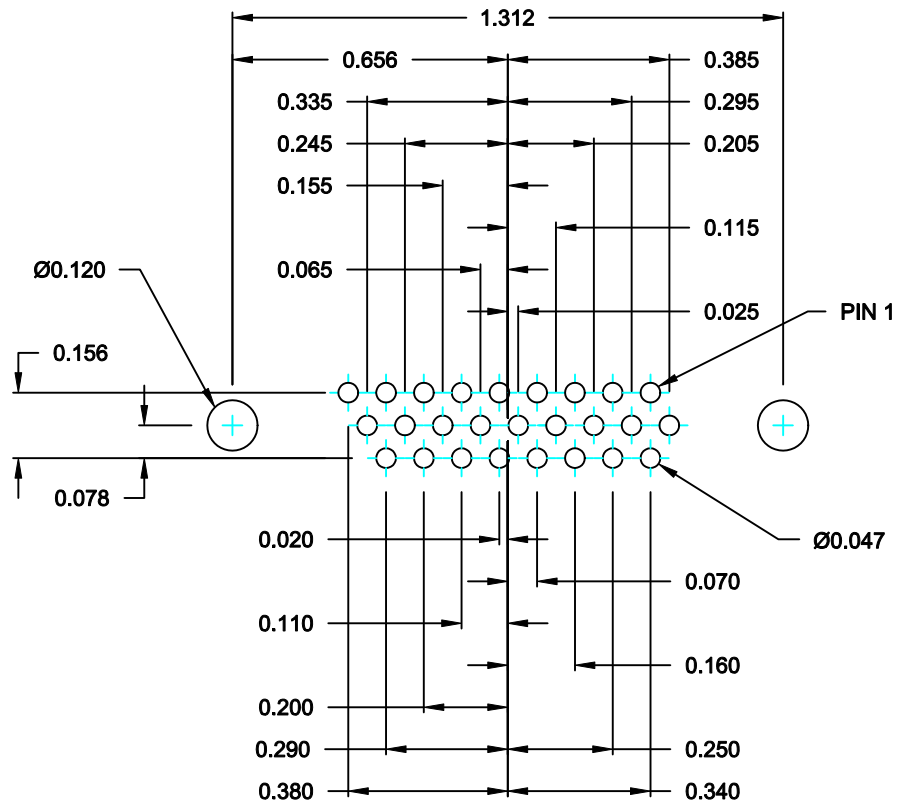

26 POSITION

DO NOT SCALE FROM DRAWING



THESE DRAWINGS AND SPECIFICATIONS ARE THE PROPERTY OF NorComp AND SHALL NOT BE REPRODUCED, COPIED OR USED AS THE BASIS FOR THE MANUFACTURE OF SALE OF APPARATUS WITHOUT WRITTEN PERMISSION.

DRAWN: **PAM JENKINS**

DATE: **10-29-01**

CHECKED:

DATE:

NorComp

SCALE: **2:1**

SHEET **2** OF **3**

REV **5**

DWG NO. **196-YYY-213-LYY1**

RoHS COMPLIANT

55X 0.158" (BOARD SIDE)

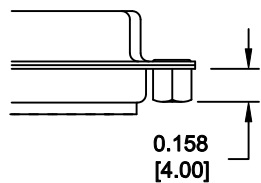

03X 0.158" (BOARD SIDE) - 0.230" MATING SIDE

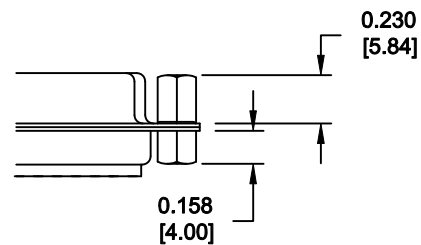

DO NOT SCALE FROM DRAWING



THESE DRAWINGS AND SPECIFICATIONS ARE THE PROPERTY OF NorComp AND SHALL NOT BE REPRODUCED, COPIED OR USED AS THE BASIS FOR THE MANUFACTURE OF SALE OF APPARATUS WITHOUT WRITTEN PERMISSION.

DRAWN: M. SIGMON		DATE: 11-19-10	
CHECKED:		DATE:	
SCALE:	SHEET 3 OF 3	REV 5	

NorComp

DWG NO. **196-YYY-213-LYY1**

RoHS COMPLIANT