

No. OF PINS	DIMENSIONS							
	A	B	C	D	E	F	G	H
15	1.213	0.984	0.666	0.329	0.090	0.756	0.496	0.429
	30.80	24.99	16.92	8.36	2.29	19.20	12.60	10.90
26	1.541	1.312	0.970	0.329	0.090	1.091	0.496	0.429
	39.15	33.32	24.65	8.36	2.29	27.70	12.60	10.90
44	2.087	1.852	1.512	0.329	0.090	1.618	0.496	0.429
	53.00	47.04	38.40	8.36	2.29	41.10	12.60	10.90

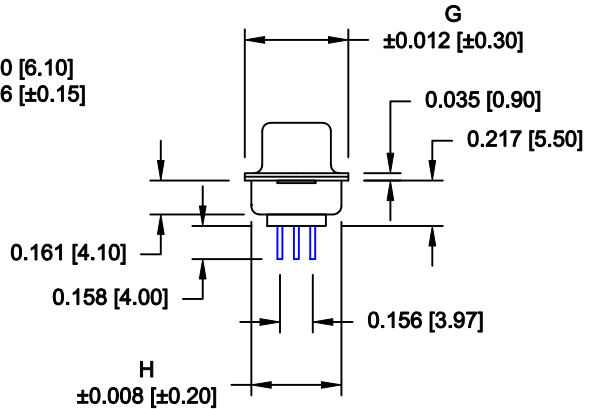
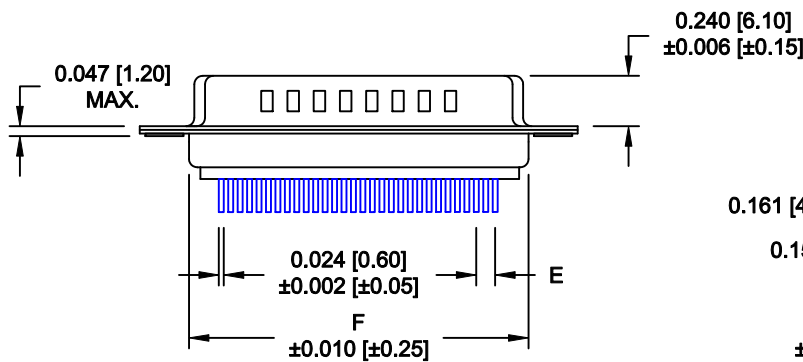

680-YYY-113RYY1

- SERIES _____
- POSITIONS _____
- 015 _____
- 026 _____
- 044 _____
- GENDER _____
- 1 = MALE
- TERMINATION _____
- 1 = VERTICAL DIP SOLDER
- SHELL PLATING _____
- 3 = NICKEL (GROUND INDENTS)
- RoHS COMPLIANT (260°C) _____
- HARDWARE OPTIONS _____
- 00 = NO HARDWARE
- 01 = .098" CLINCH NUT (BOARD SIDE)
- 02 = .236" CLINCH NUT (BOARD SIDE)
- 03 = .236" CLINCH NUT (MATING SIDE)
- 05 = .237 4-40 BOARD LOCK
- PLATING OPTIONS _____
- 1 = GOLD FLASH
- 2 = 30u" GOLD

MATERIAL:

- SHELL: STEEL, NICKEL PLATED
- INSULATOR: PBT, UL 94V-O RATED, +30% FIBER-GLASS OR NYLON-66
- CONTACT: BRASS, GOLD PLATED OVER NICKEL
- SEALING MATERIAL: F08 FLEXIBLE ADHESIVE

ELECTRICAL:

- CURRENT RATING: 5 AMPS
- CONTACT RESISTANCE: 15 mOhms Max.
- INSULATION RESISTANCE: 1,000 MOhms min.
- VOLTAGE: 500VAC FOR 1 MINUTE
- TEMPERATURE: -50° C TO 100° C

MEETS IP66 STANDARDS
(SEE PAGE 4 FOR SEALING DETAILS)

DO NOT SCALE FROM DRAWING

RoHS COMPLIANT

	THESE DRAWINGS AND SPECIFICATIONS ARE THE PROPERTY OF NorComp AND SHALL NOT BE REPRODUCED, COPIED OR USED AS THE BASIS FOR THE MANUFACTURE OF SALE OF APPARATUS WITHOUT WRITTEN PERMISSION.		DRAWN: M. SIGMON	DATE: 08-23-11
			CHECKED:	DATE:
NorComp		SCALE: 1 : 1	SHEET 1 OF 4	REV 1
		DWG NO. 680-YYY-113RYY1		

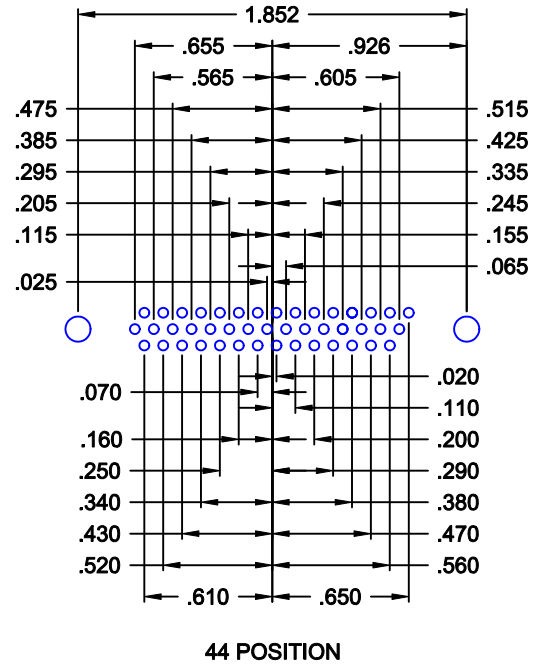
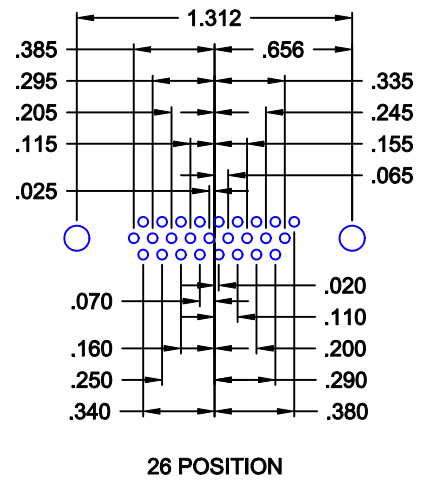
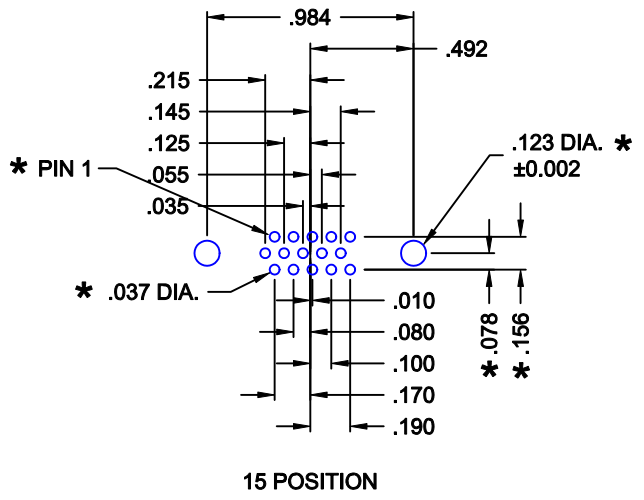

180 SERIES
HIGH DENSITY
VERTICAL

HOLE PATTERN SHOWN
ARE FOR MALE

* TYP. ON ALL SIZES

DO NOT SCALE FROM DRAWING

	THESE DRAWINGS AND SPECIFICATIONS ARE THE PROPERTY OF NorComp AND SHALL NOT BE REPRODUCED, COPIED OR USED AS THE BASIS FOR THE MANUFACTURE OF SALE OF APPARATUS WITHOUT WRITTEN PERMISSION.		DRAWN: M. SIGMON	DATE: 08-23-11
			CHECKED:	DATE:
<h1>NorComp</h1>		SCALE:	SHEET 2 OF 4	REV 1
		DWG NO. 680-YYY-113RYY1		

ALL CLINCH-NUTS ARE 4-40 INTERNAL THREADS

01X 0.098" (BOARD SIDE) - CN1

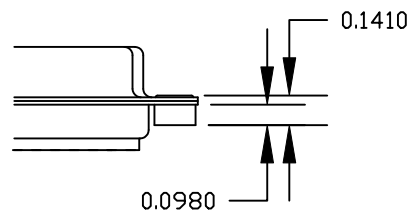

02X 0.236" (BOARD SIDE) - CN2

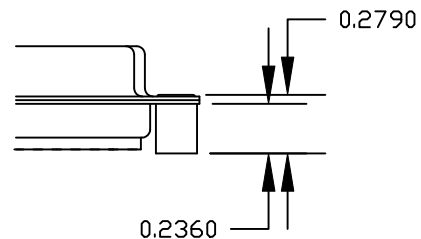

03X..... 0.236" (MATING SIDE) - CN8

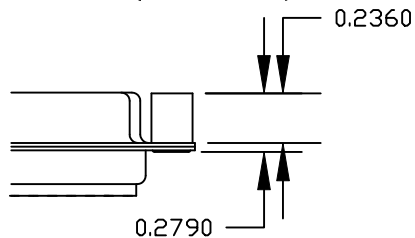

05X 0.237" (BOARD SIDE) - CN10

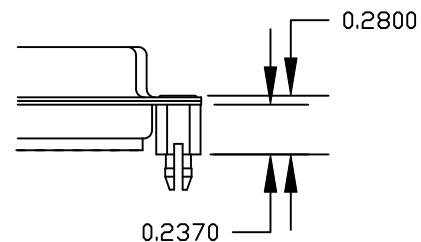

DO NOT SCALE FROM DRAWING



THESE DRAWINGS AND SPECIFICATIONS ARE THE PROPERTY OF NorComp AND SHALL NOT BE REPRODUCED, COPIED OR USED AS THE BASIS FOR THE MANUFACTURE OF SALE OF APPARATUS WITHOUT WRITTEN PERMISSION.

DRAWN:
M. SIGMON

DATE:
08-23-11

CHECKED:

DATE:

NorComp

SCALE: SHEET **3** OF **4** REV **1**

DWG NO. **680-YYY-113RYY1**

RoHS COMPLIANT

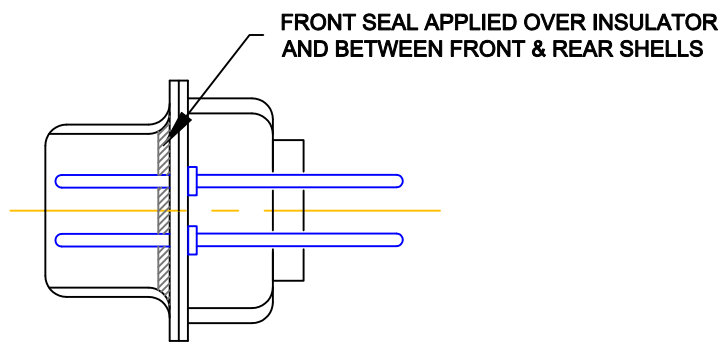
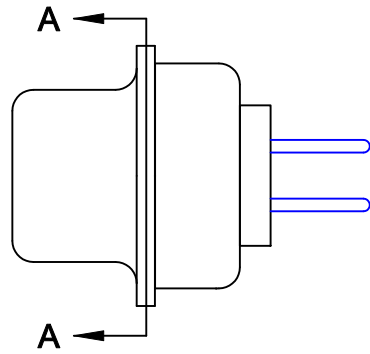

DETAIL A-A

DO NOT SCALE FROM DRAWING

	THESE DRAWINGS AND SPECIFICATIONS ARE THE PROPERTY OF NorComp AND SHALL NOT BE REPRODUCED, COPIED OR USED AS THE BASIS FOR THE MANUFACTURE OF SALE OF APPARATUS WITHOUT WRITTEN PERMISSION.		DRAWN: M. SIGMON	DATE: 08-23-11	
			CHECKED:	DATE:	
<h1>NorComp</h1>			SCALE:	SHEET 4 OF 4	REV 1
			DWG NO. 680-YYY-113RYY1		

RoHS COMPLIANT