

DESCRIPTION: HIGH DENSITY - MALE - RIGHT ANGLE - SEALED

44 PIN SHOWN

DIMENSIONS (IN.)							
No. OF PINS	A	B	C	D	E	F	G
15	1.213	0.984	0.666	0.090	0.329	0.496	0.639
	30.80	24.99	16.92	2.29	8.36	12.60	16.23
26	1.543	1.312	0.994	0.090	0.329	0.496	0.639
	39.19	33.32	25.25	2.29	8.36	12.60	16.23
44	2.087	1.852	1.534	0.090	0.329	0.496	0.639
	53.00	47.04	38.96	2.29	8.36	12.60	16.23

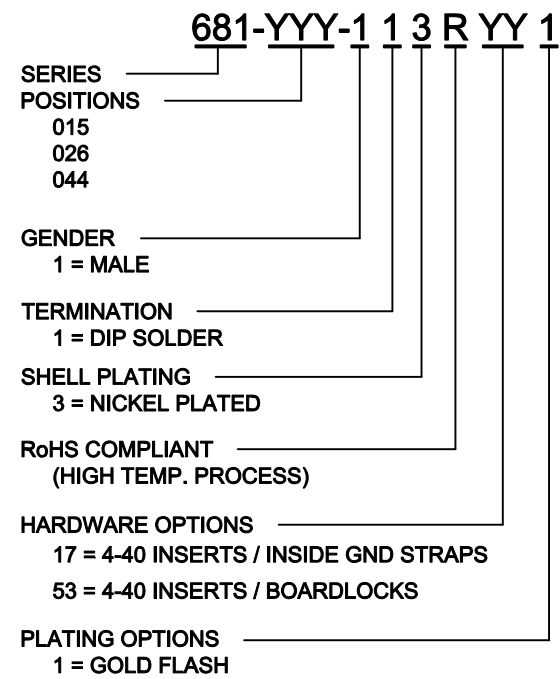
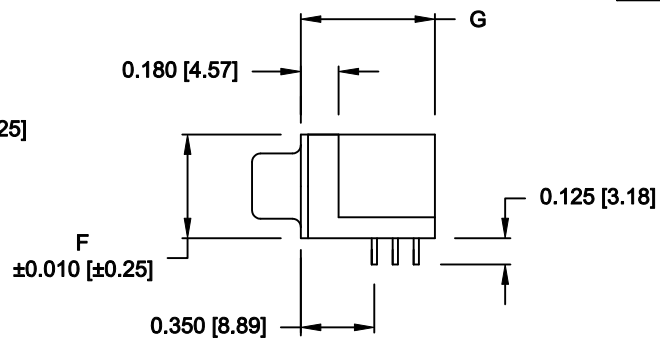
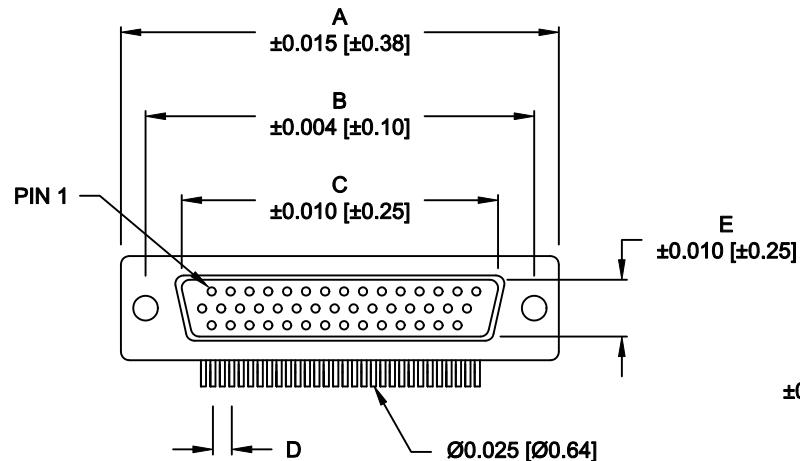

ELECTRICAL:
 CURRENT RATING: 2 AMPS
 CONTACT RESISTANCE: 15 MILLIOhms Max.
 INSULATION RESISTANCE: 1,000 MEGOhms Min.
 VOLTAGE: 500V FOR 1 MINUTE
 TEMPERATURE: -50°C TO +100°C

MEETS IP66 STANDARDS
 (SEE PAGE 3 FOR SEALING DETAILS)

MATERIALS:
 SHELL: SPCC, NICKEL PLATED
 INSULATOR: PA 9T-BLACK (UL94-0)
 260°C PROCESS TEMPERATURE
 CONTACT: BRASS, GOLD ENTIRE CONTACT
 RIVET: COPPER ALLOY, NICKEL PLATED
 BOARDLOCK: SPCC, TIN PLATED
 SCREWLOCK: ZINC ALLOY, NICKEL PLATED
 SEAL: F08 FLEXIBLE ADHESIVE

DO NOT SCALE FROM DRAWING

RoHS COMPLIANT

	THESE DRAWINGS AND SPECIFICATIONS ARE THE PROPERTY OF NorComp AND SHALL NOT BE REPRODUCED, COPIED OR USED AS THE BASIS FOR THE MANUFACTURE OR SALE OF APPARATUS WITHOUT WRITTEN PERMISSION.		DRAWN: P. JENKINS CHECKED:	DATE: 11-24-11 DATE:
	NorComp		SCALE:	SHEET 1 OF 3
DWG NO. 681-YYY-113RYY1				

DESCRIPTION: PCB LAYOUT - RIGHT ANGLE - MALE

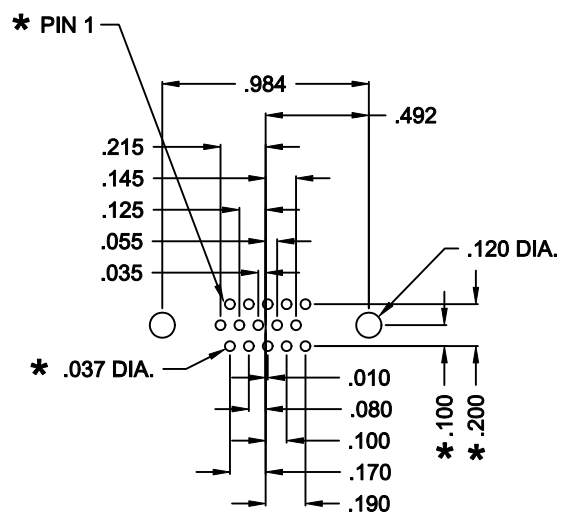

15 POSITION

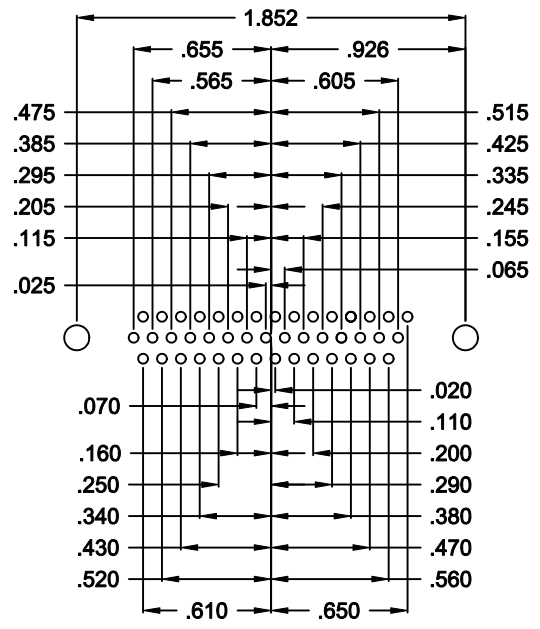

44 POSITION

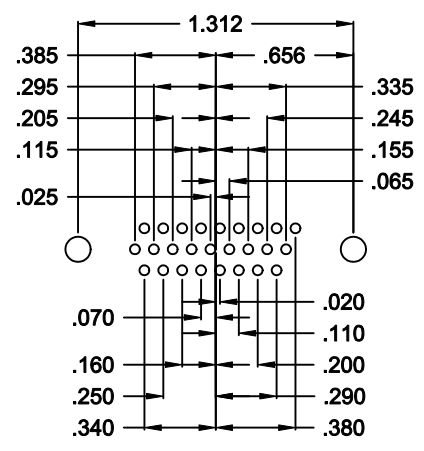

26 POSITION

**181 SERIES
HIGH DENSITY
RIGHT ANGLE**

**HOLE PATTERN SHOWN
ARE FOR MALE**

*** TYP. ON ALL SIZES**

DO NOT SCALE FROM DRAWING

	THESE DRAWINGS AND SPECIFICATIONS ARE THE PROPERTY OF NorComp AND SHALL NOT BE REPRODUCED, COPIED OR USED AS THE BASIS FOR THE MANUFACTURE OR SALE OF APPARATUS WITHOUT WRITTEN PERMISSION.		DRAWN: P. JENKINS	DATE: 11-24-11
			CHECKED:	DATE:
<h1>NorComp</h1>		SCALE: FULL	SHEET 2 OF 3	REV 1
		DWG NO. 681-YYY-113RYY1		

DESCRIPTION: HIGH DENSITY R/A HARDWARE OPTIONS

SEALING PROCESS

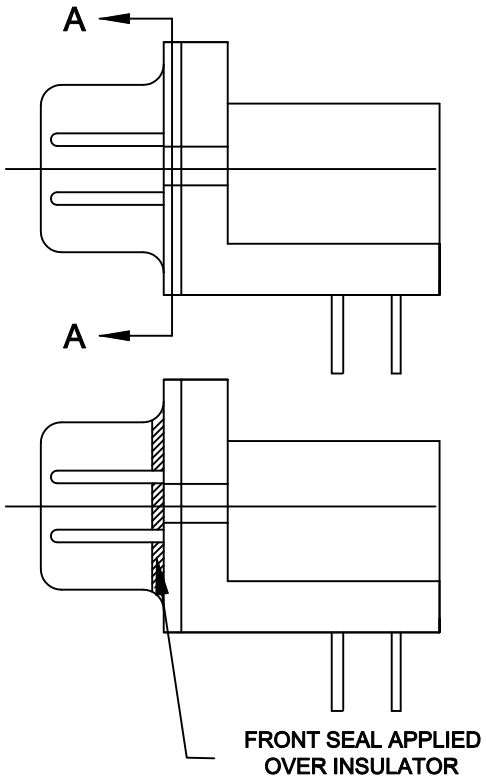

DETAIL A-A

SHOWN FOR REFERENCE ONLY

HARDWARE OPTIONS

	<p>0.141 ±0.020</p> <p>METAL SHELL WITH INSIDE GROUND STRAPS</p>	<p>METAL SHELL FORK BOARD LOCKS</p>
<p>4-40 FLUSH INSERT</p>	17	<p>53</p> <p>BOARD LOCKS IN FRONT HOLE</p>



THESE DRAWINGS AND SPECIFICATIONS ARE THE PROPERTY OF NorComp AND SHALL NOT BE REPRODUCED, COPIED OR USED AS THE BASIS FOR THE MANUFACTURE OR SALE OF APPARATUS WITHOUT WRITTEN PERMISSION.

DRAWN: P. JENKINS

DATE: 11-24-11

CHECKED:

DATE:

SCALE:

SHEET 3 OF 3

REV 1

DWG NO. 681-YYY-113RYY1

RoHS COMPLIANT

NorComp