

DESCRIPTION: FEMALE - SOLDER CUP - MACHINED - ECONOMY

WILL ACCEPT
26-20 AWG WIRE

No. OF PINS	DIMENSIONS							
	A	B	C	D	E	F	G	H
9	1.213	0.984	0.642	0.311	0.236	0.756	0.496	0.427
	30.80	24.99	16.30	7.90	5.99	19.20	12.60	10.85
15	1.541	1.312	0.970	0.311	0.236	1.091	0.496	0.427
	39.15	33.32	24.65	7.90	5.99	27.70	12.60	10.85
25	2.083	1.874	1.512	0.311	0.236	1.630	0.496	0.427
	52.91	47.60	38.41	7.90	5.99	41.40	12.60	10.85

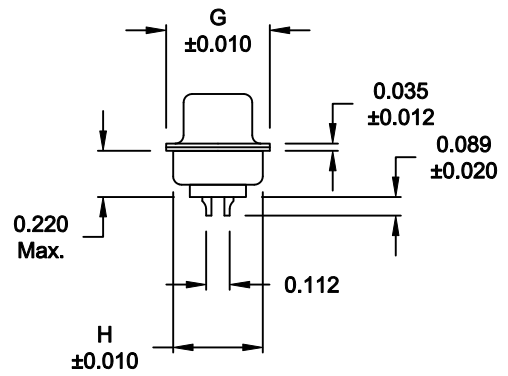
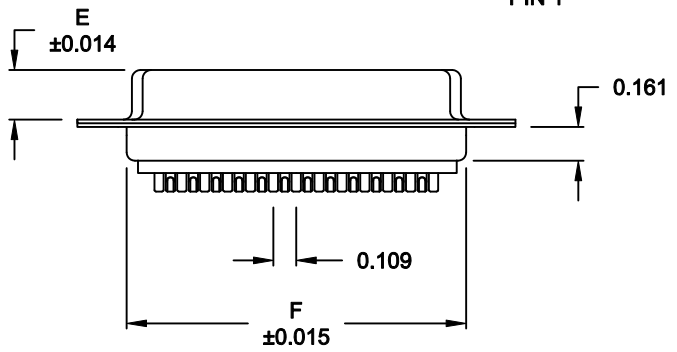
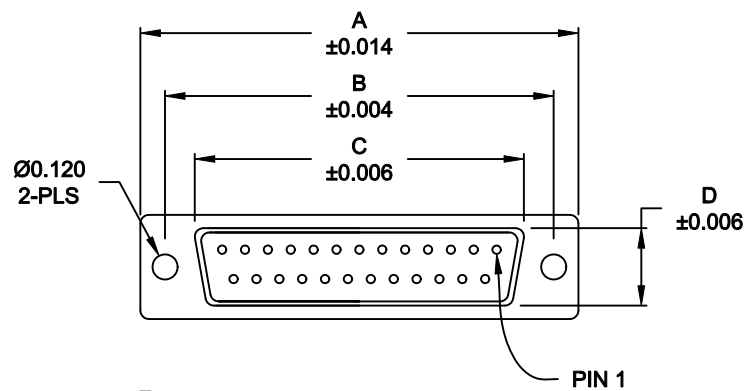

772-EYY-20YRYY1

SERIES ————
POSITIONS ————
E09
E15
GENDER ————
2 = FEMALE
TERMINATION ————
0 = SOLDER CUP
SHELL PLATING ————
2 = TIN
3 = NICKEL
RoHS COMPLIANT ————
HARDWARE OPTIONS ————
00 = NO HARDWARE
01 = 0.065" CLINCH NUT, BOARD SIDE
PLATING OPTIONS ————
1 = GOLD FLASH

MATERIAL:

- SHELL: STEEL, NICKEL OR TIN PLATED
- INSULATOR: UL 94V-O RATED PBT-WHITE
- PROCESS TEMP.: 260° C
- CONTACT: BRASS
- SEALING MATERIAL: F04 FLEXABLE ADHESIVE

ELECTRICAL:

- CURRENT RATING: 5 AMPS
- CONTACT RESISTANCE: 15 mOhms Max.
- INSULATION RESISTANCE: 1,000 MOhms min.
- VOLTAGE: 500VAC FOR 1 MINUTE
- TEMPERATURE: -50° C TO 100° C

MEETS IP67 STANDARDS

(SEE PAGE 2 FOR SEALING DETAILS)

DO NOT SCALE FROM DRAWING

	THESE DRAWINGS AND SPECIFICATIONS ARE THE PROPERTY OF NorComp AND SHALL NOT BE REPRODUCED, COPIED OR USED AS THE BASIS FOR THE MANUFACTURE OR SALE OF APPARATUS WITHOUT WRITTEN PERMISSION.		DRAWN: C. SMITH	DATE: 03-26-09
			CHECKED:	DATE:
NorComp		SCALE: 1:1	SHEET 1 OF 2	REV 3
		DWG NO. 772-EYY-20YRYY1		

RoHS COMPLIANT

DESCRIPTION: IP67 - FEMALE - SOLDER CUP - MACHINED - ECONOMY - SEALING PROCESS

HARDWARE OPTION

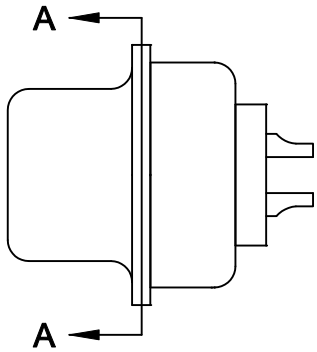

01X 0.065" (BOARD SIDE) - CN1

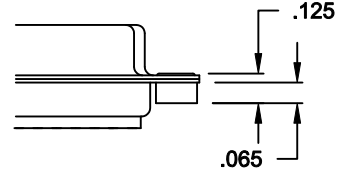

FRONT SEAL APPLIED BETWEEN FRONT INSULATOR AND FRONT METAL SHELL

MIDDLE SEAL APPLIED BETWEEN FRONT INSULATOR AND BACK INSULATOR

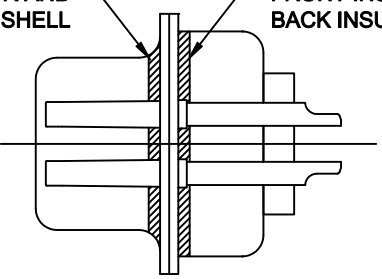

DETAIL A-A

DO NOT SCALE FROM DRAWING

	THESE DRAWINGS AND SPECIFICATIONS ARE THE PROPERTY OF NorComp AND SHALL NOT BE REPRODUCED, COPIED OR USED AS THE BASIS FOR THE MANUFACTURE OR SALE OF APPARATUS WITHOUT WRITTEN PERMISSION.		DRAWN: C. SMITH	DATE: 03-26-09
			CHECKED:	DATE:
<h1>NorComp</h1>		SCALE: 2.5 : 1	SHEET 2 OF 2	REV 3
		DWG NO. 772-EYY-20YRYY1		