

DESCRIPTION: MALE - HIGH DENSITY - MACHINED CONTACTS - SOLDER CUP

MATERIAL:

SHELL: STEEL MATERIAL, NICKEL FINISH
 INSULATOR: PBT THERMOPLASTIC 30% GLASS FILLED, UL 94V-0 RATED, BLACK
 CONTACT MATERIAL: BRASS
 CONTACT FINISH: SELECTIVE GOLD FINISHED
 SEALING MATERIAL: F08 FLEXIBLE ADHESIVE

ELECTRICAL:

CONTACT CURRENT RATING: 5 AMPS
 CONTACT RESISTANCE: 30 Milliohms Max.
 DIELECTRIC WITHSTANDING VOLTAGE: 1,000VAC Min.
 INSULATION RESISTANCE: 5,000 Megohms Min.
 TEMPERATURE RATING: -55° ~ +105° C

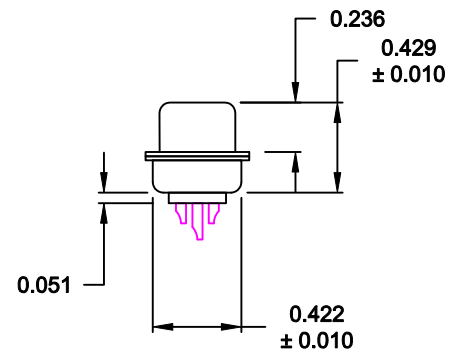
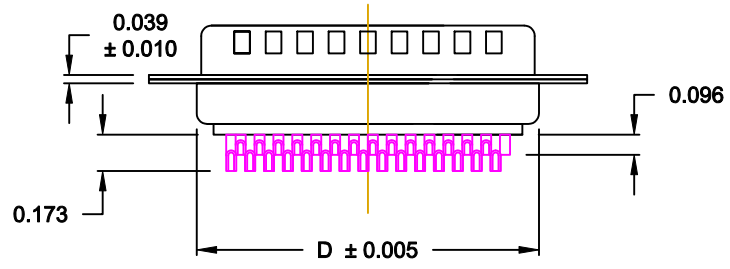
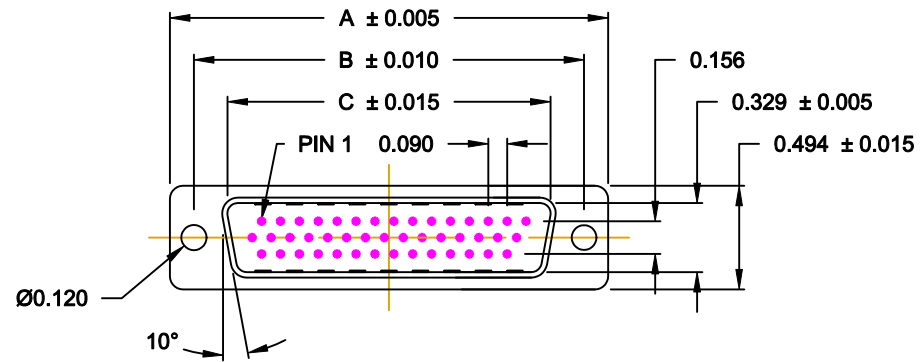

ACCEPTS 28 - 24 AWG WIRE

DIMENSIONS (IN.)				
No. OF PINS	A	B	C	D
15	1.213	0.984	0.666	0.759
26	1.541	1.312	0.994	1.083
44	2.088	1.852	1.534	1.625

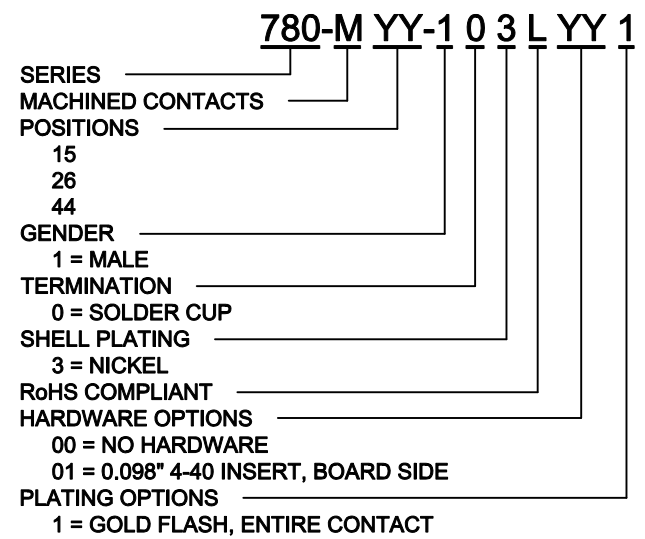

MEETS IP67 STANDARDS

(SEE PAGE 2 FOR SEALING DETAILS)



DO NOT SCALE FROM DRAWING

RoHS COMPLIANT

	THESE DRAWINGS AND SPECIFICATIONS ARE THE PROPERTY OF NorComp AND SHALL NOT BE REPRODUCED, COPIED OR USED AS THE BASIS FOR THE MANUFACTURE OF SALE OF APPARATUS WITHOUT WRITTEN PERMISSION.		DRAWN: C. SMITH	DATE: 06-11-09
			CHECKED:	DATE:
		SCALE: 1 : 1	SHEET 1 OF 2	REV 3
		DWG NO. 780-MYY-103LYY1		

HARDWARE OPTION

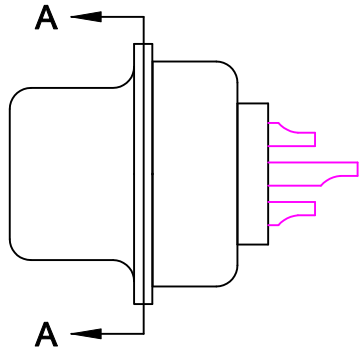

FRONT SEAL APPLIED OVER INSULATOR AND BETWEEN FRONT & REAR SHELLS

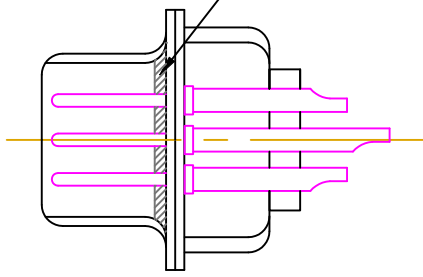

DETAIL A-A

01X 0.065" (BOARD SIDE) - CN1

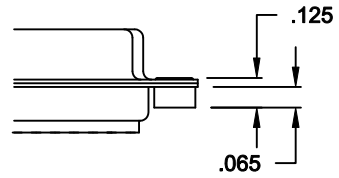

DO NOT SCALE FROM DRAWING

	THESE DRAWINGS AND SPECIFICATIONS ARE THE PROPERTY OF NorComp AND SHALL NOT BE REPRODUCED, COPIED OR USED AS THE BASIS FOR THE MANUFACTURE OR SALE OF APPARATUS WITHOUT WRITTEN PERMISSION.		DRAWN: C. SMITH	DATE: 03-26-09
			CHECKED:	DATE:
<h1>NorComp</h1>		SCALE: 2.5 : 1	SHEET 2 OF 2	REV 3
		DWG NO. 780-MYY-103LYY1		