

DESCRIPTION: MALE - HIGH DENSITY - MACHINED CONTACTS - VERTICAL

MATERIALS AND FINISH:

SHELL: STEEL MATERIAL, NICKEL FINISH
 INSULATOR: PA6T = 260°C, UL 94V-0 RATED, BLACK
 CONTACT MATERIAL: BRASS
 CONTACT FINISH: FULL GOLD FLASH
 SEAL MATERIAL: F08 FLEXIBLE ADHESIVE

ELECTRICAL:

CONTACT CURRENT RATING: 5 AMPS
 CONTACT RESISTANCE: 30 Milliohms Max.
 DIELECTRIC WITHSTANDING VOLTAGE: 1,000VAC Min.
 INSULATION RESISTANCE: 5,000 Megohms Min.
 TEMPERATURE RATING: -55° ~ +105° C

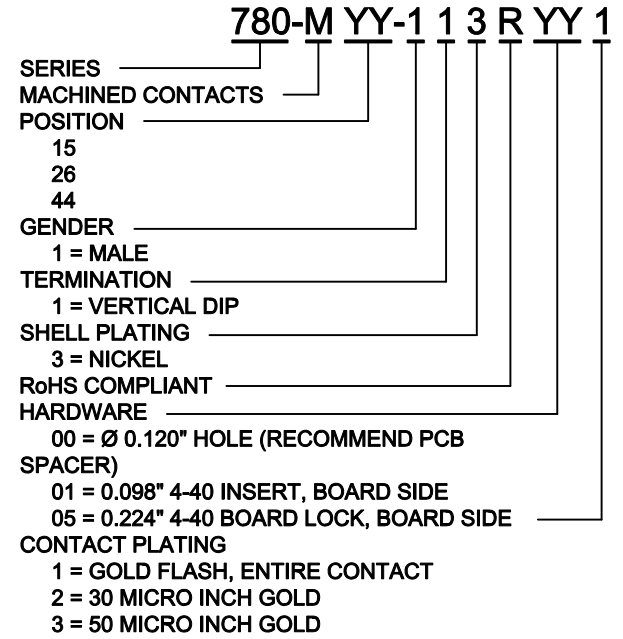
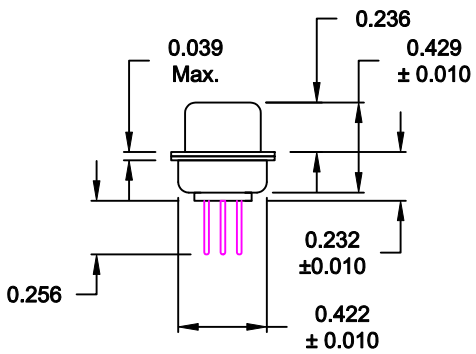
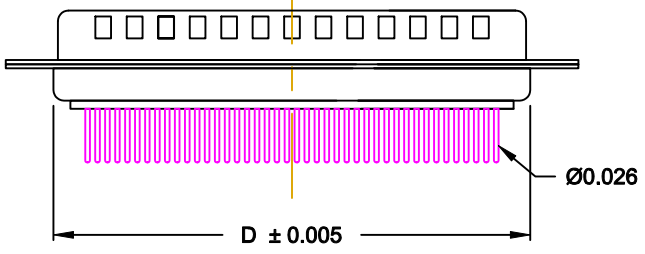
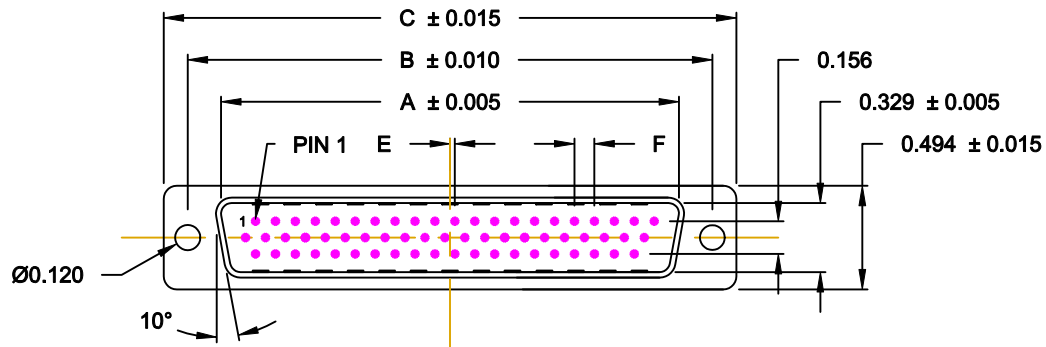

DIMENSIONS (IN.)						
No. OF PINS	A	B	C	D	E	F
15	0.666	0.984	1.213	0.759	0.010	0.090
25	0.994	1.312	1.541	1.083	0.020	0.090
44	1.534	1.852	2.088	1.625	0.020	0.090

MEETS IP67 STANDARDS

(SEE PAGE 3 FOR SEALING DETAILS)

DO NOT SCALE FROM DRAWING

	THESE DRAWINGS AND SPECIFICATIONS ARE THE PROPERTY OF NorComp AND SHALL NOT BE REPRODUCED, COPIED OR USED AS THE BASIS FOR THE MANUFACTURE OF SALE OF APPARATUS WITHOUT WRITTEN PERMISSION.		DRAWN: P. JENKINS	DATE: 06-08-09
			CHECKED:	DATE:
<h1>NorComp</h1>		SCALE: 1 : 1	SHEET 1 OF 4	REV 8
		DWG NO. 780-MYY-113RYY1		

RoHS COMPLIANT

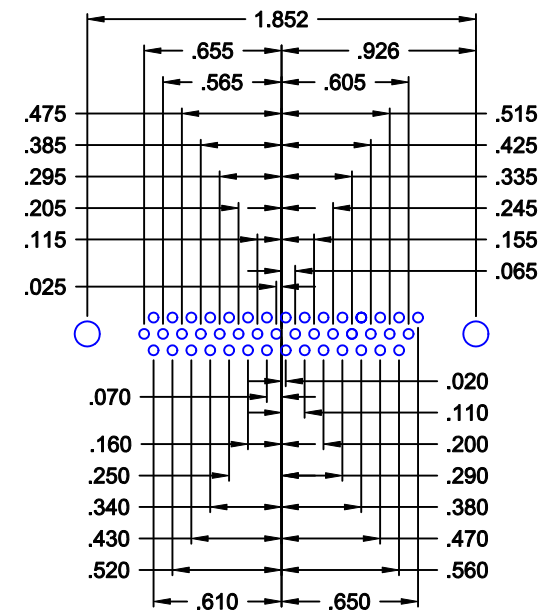
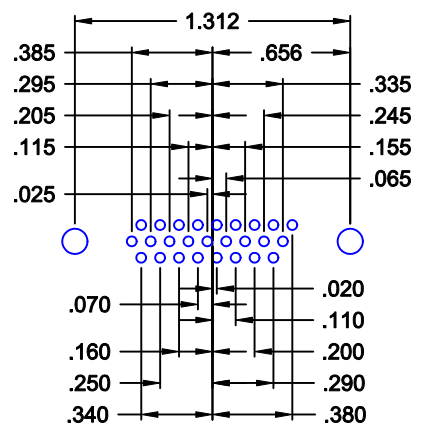
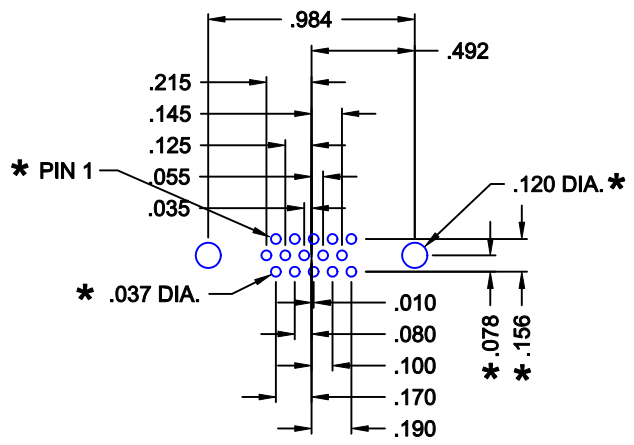

* TYP. ON ALL SIZES

DO NOT SCALE FROM DRAWING

	THESE DRAWINGS AND SPECIFICATIONS ARE THE PROPERTY OF NorComp AND SHALL NOT BE REPRODUCED, COPIED OR USED AS THE BASIS FOR THE MANUFACTURE OF SALE OF APPARATUS WITHOUT WRITTEN PERMISSION.		DRAWN: P. JENKINS	DATE: 06-08-09
			CHECKED:	DATE:
<h1>NorComp</h1>		SCALE: 1 : 1	SHEET 2 OF 4	REV 8
		DWG NO. 780-MYY-113RYY1		

ALL CLINCH-NUTS ARE 4-40 INTERNAL THREADS

01X 0.098" (BOARD SIDE) - CN1

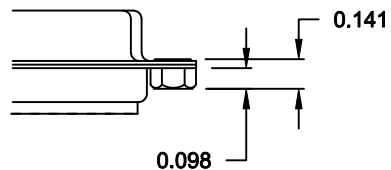

05X 0.237" BOARD SIDE - CN10

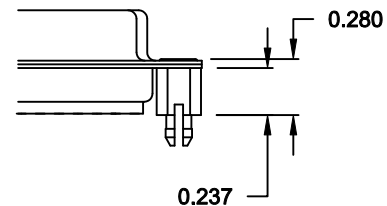

DO NOT SCALE FROM DRAWING

	THESE DRAWINGS AND SPECIFICATIONS ARE THE PROPERTY OF NorComp AND SHALL NOT BE REPRODUCED, COPIED OR USED AS THE BASIS FOR THE MANUFACTURE OF SALE OF APPARATUS WITHOUT WRITTEN PERMISSION.		DRAWN: M. SIGMON	DATE: 12-10-10
			CHECKED:	DATE:
<h1>NorComp</h1>		SCALE:	SHEET 3 OF 4	REV 8
		DWG NO. 780-MYY-113RYY1		

RoHS COMPLIANT

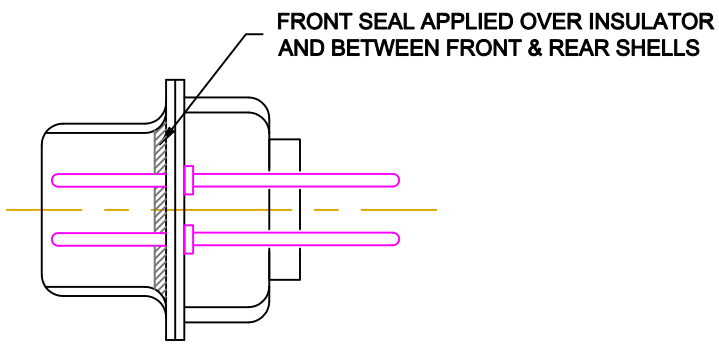
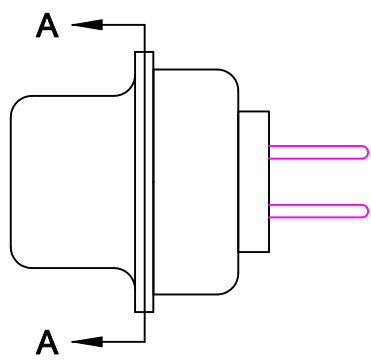

FRONT SEAL APPLIED OVER INSULATOR AND BETWEEN FRONT & REAR SHELLS

DETAIL A-A

DO NOT SCALE FROM DRAWING

	THESE DRAWINGS AND SPECIFICATIONS ARE THE PROPERTY OF NorComp AND SHALL NOT BE REPRODUCED, COPIED OR USED AS THE BASIS FOR THE MANUFACTURE OF SALE OF APPARATUS WITHOUT WRITTEN PERMISSION.		DRAWN: C. SMITH	DATE: 06-10-09
			CHECKED:	DATE:
NorComp		SCALE: 2.5 : 1	SHEET 4 OF 4	REV 8
		DWG NO. 780-MYY-113RYY1		