

DESCRIPTION: MALE - HIGH DENSITY - MACHINED CONTACTS - RIGHT ANGLE

**MATERIAL:**

SHELL: STEEL MATERIAL, NICKEL FINISH  
 INSULATOR: PA6T=260°C, UL 94V-0 RATED, BLACK  
 CONTACT MATERIAL: BRASS  
 CONTACT FINISH: SELECTIVE GOLD FINISHED  
 SEALING MATERIAL: F08 FLEXIBLE ADHESIVE

**ELECTRICAL:**

CONTACT CURRENT RATING: 5 AMPS  
 CONTACT RESISTANCE: 30 Milliohms Max.  
 DIELECTRIC WITHSTANDING VOLTAGE: 1,000VAC Min.  
 INSULATION RESISTANCE: 5,000 Megohms Min.  
 TEMPERATURE RATING: -55° ~ +105° C

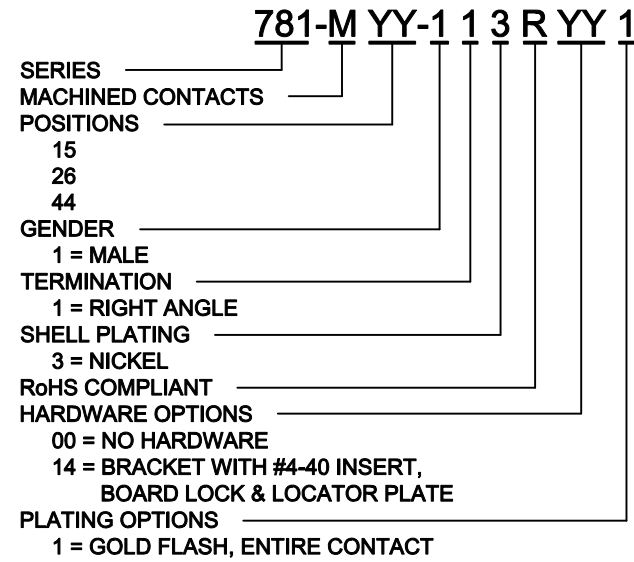
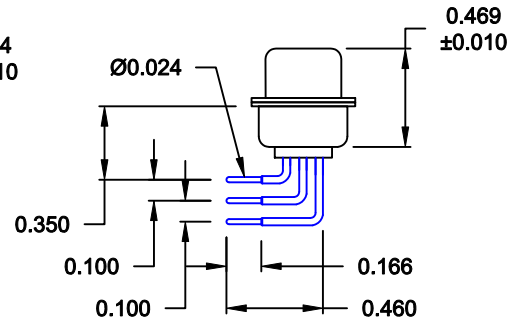
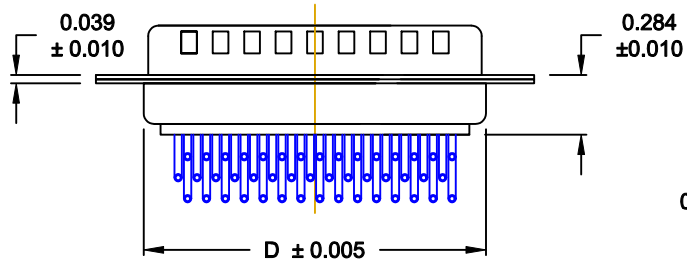
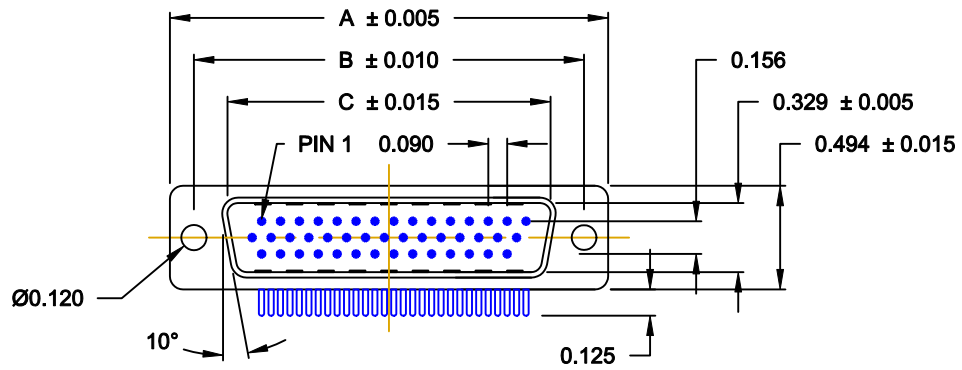

DIMENSIONS (IN.)				
No. OF PINS	A	B	C	D
15	1.213	0.984	0.666	0.759
26	1.541	1.312	0.994	1.083
44	2.088	1.852	1.534	1.625

**MEETS IP67 STANDARDS**

(SEE PAGE 4 FOR SEALING DETAILS)

**DO NOT SCALE FROM DRAWING**

	THESE DRAWINGS AND SPECIFICATIONS ARE THE PROPERTY OF NorComp AND SHALL NOT BE REPRODUCED, COPIED OR USED AS THE BASIS FOR THE MANUFACTURE OF SALE OF APPARATUS WITHOUT WRITTEN PERMISSION.		DRAWN: <b>C. SMITH</b>	DATE: <b>03-16-07</b>
			CHECKED:	DATE:
		SCALE: <b>1:1</b>	SHEET <b>1</b> OF <b>4</b>	REV <b>2</b>
		DWG NO. <b>781-MYY-113RYY1</b>		

**RoHS COMPLIANT**

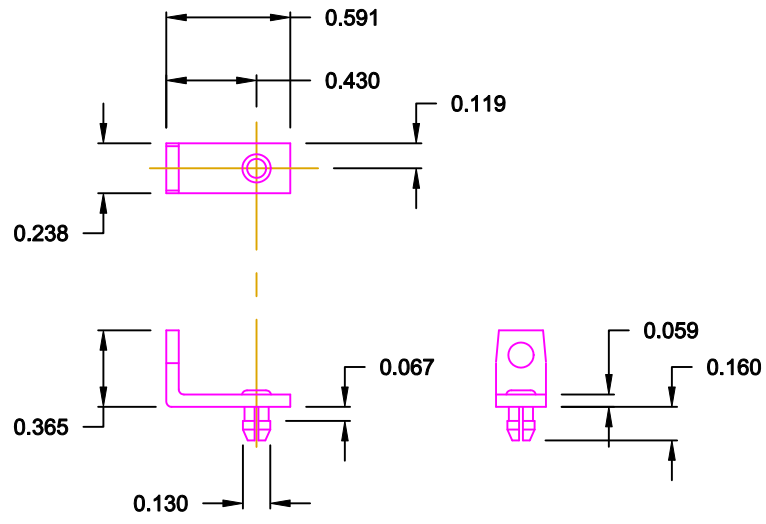

**MOUNTING BRACKET  
WITH BOARD LOCK**  
HARDWARE OPTION 14

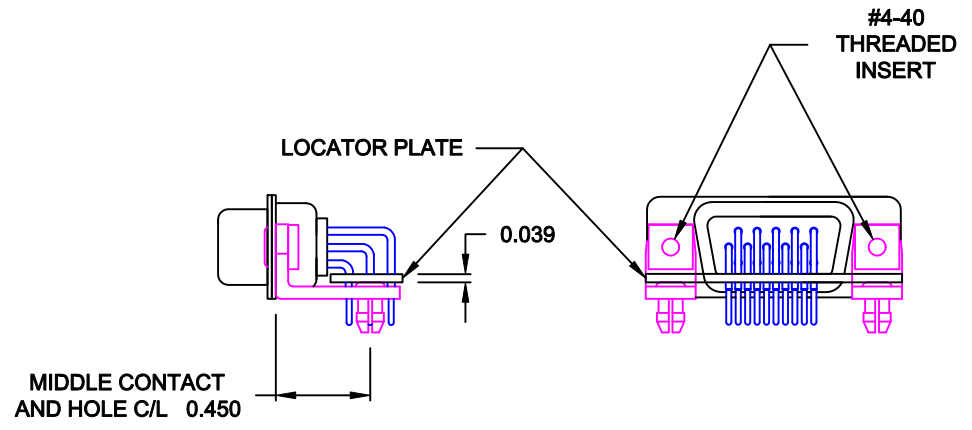

**BRACKETS MOUNTED ON CONNECTOR  
WITH LOCATOR PLATE**  
HARDWARE OPTION 14

**FOR CLARITY  
HIDDEN LINES  
NOT SHOWN**

**MATERIAL:** COLD ROLLED STEEL  
**PLATING:** CLEAR ZINC

	THESE DRAWINGS AND SPECIFICATIONS ARE THE PROPERTY OF NorComp AND SHALL NOT BE REPRODUCED, COPIED OR USED AS THE BASIS FOR THE MANUFACTURE OF SALE OF APPARATUS WITHOUT WRITTEN PERMISSION.		DRAWN: <b>PAM JENKINS</b>	DATE: <b>11-28-05</b>	
			CHECKED:	DATE:	
NorComp		SCALE: <b>1 : 1</b>	SHEET <b>2</b>	OF <b>4</b>	REV <b>2</b>
		DWG NO. <b>781-MYY-113RYY1</b>			

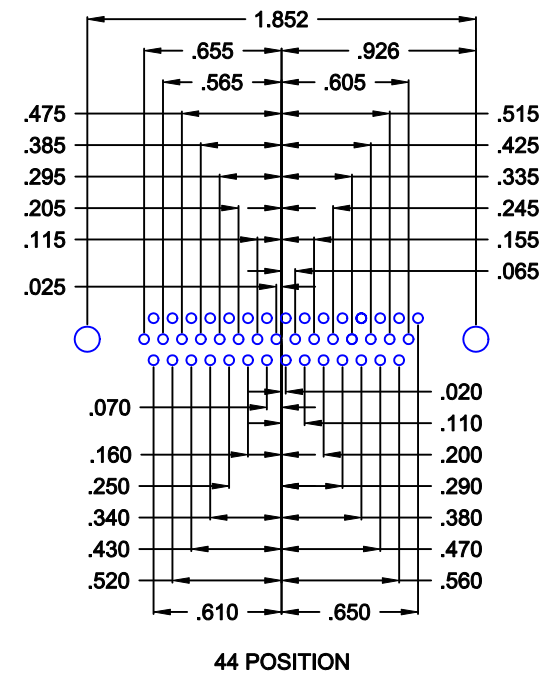
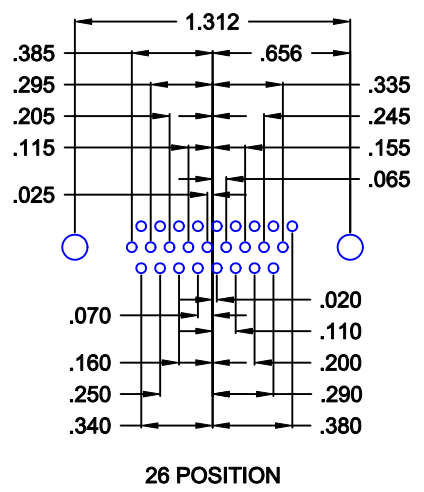
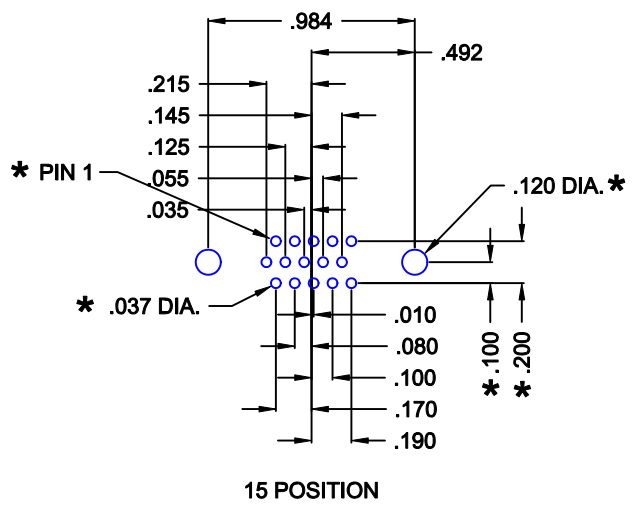

\* TYP. ON ALL SIZES

DO NOT SCALE FROM DRAWING

	THESE DRAWINGS AND SPECIFICATIONS ARE THE PROPERTY OF NorComp AND SHALL NOT BE REPRODUCED, COPIED OR USED AS THE BASIS FOR THE MANUFACTURE OF SALE OF APPARATUS WITHOUT WRITTEN PERMISSION.		DRAWN: <b>C. SMITH</b>	DATE: <b>03-16-07</b>
			CHECKED:	DATE:
NorComp		SCALE: <b>1 : 1</b>	SHEET <b>3</b>	OF <b>4</b>
		DWG NO. <b>781-MYY-113RYY1</b>		

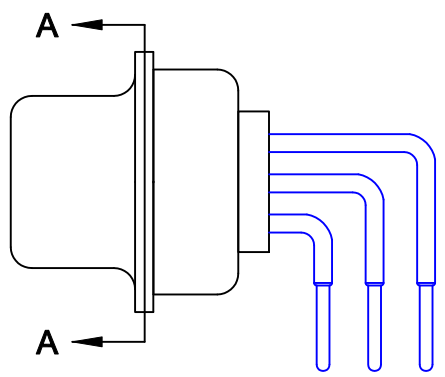

FRONT SEAL APPLIED OVER INSULATOR AND BETWEEN FRONT & REAR SHELLS

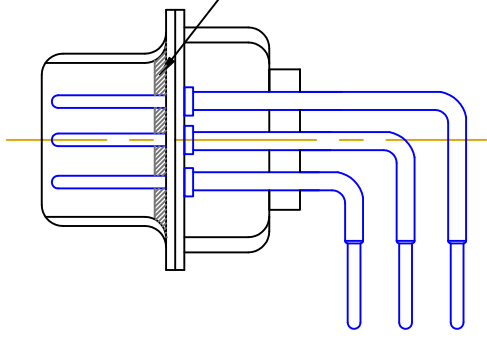

DETAIL A-A

DO NOT SCALE FROM DRAWING

	THESE DRAWINGS AND SPECIFICATIONS ARE THE PROPERTY OF NorComp AND SHALL NOT BE REPRODUCED, COPIED OR USED AS THE BASIS FOR THE MANUFACTURE OF SALE OF APPARATUS WITHOUT WRITTEN PERMISSION.		DRAWN: <b>C. SMITH</b>	DATE: <b>06-10-09</b>
			CHECKED:	DATE:
<h1>NorComp</h1>		SCALE: <b>2.5 : 1</b>	SHEET <b>4</b> OF <b>4</b>	REV <b>2</b>
		DWG NO. <b>781-MYY-113RYY1</b>		