

DESCRIPTION: POWER - SOLDER CUP - MALE

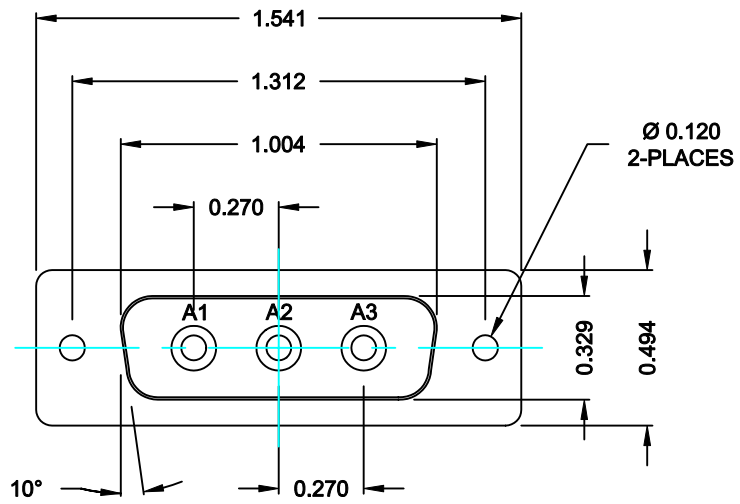

**SPECIFICATIONS:**

**ELECTRICAL:**  
 INSULATOR RESISTANCE: 5,000 MegOHMS Min.  
 DIELECTRIC WITHSTANDING: 1,000VAC r.m.s.  
 OPERATING TEMPERATURE: -55° C ~ +125° C  
 CONTACT RESISTANCE: 30 MilliOHMS Max.  
 POWER PINS: SEE PART No. BELOW

**MECHANICAL:**  
 CONTACT INSERTION FORCE: 4.5 Kg Max.  
 CONTACT SEPARATOR FORCE: 0.3Kg Min.

**MATERIALS:**  
 CONTACTS: BRASS  
 INSULATOR: PBT UL94V-0 RATED,  
 230°C PROCESS TEMP.  
 SHELL: STEEL

**FINISH:**  
 SHELL: NICKEL

**6803W3103LYY1**

20 = 20 AMPS  
 40 = 40 AMPS

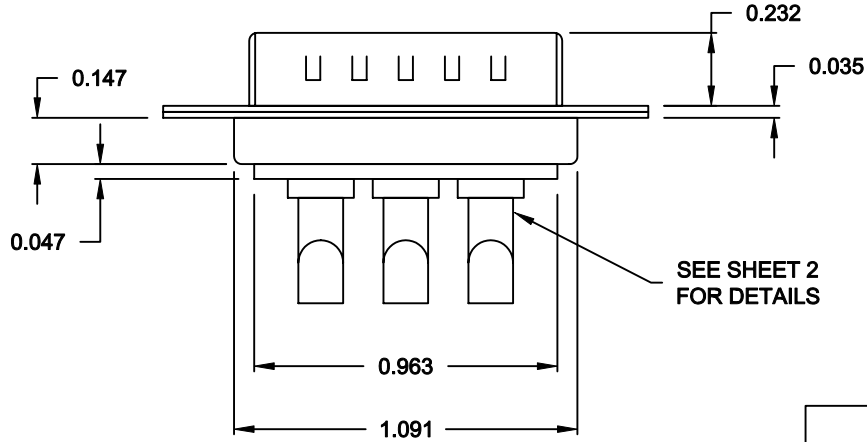

**RoHS COMPLIANT**

	THESE DRAWINGS AND SPECIFICATIONS ARE THE PROPERTY OF NorComp AND SHALL NOT BE REPRODUCED, COPIED OR USED AS THE BASIS FOR THE MANUFACTURE OF SALE OF APPARATUS WITHOUT WRITTEN PERMISSION.		DRAWN: <b>C. SMITH</b>	DATE: <b>09-11-06</b>
			CHECKED: <b>X</b>	DATE: <b>X</b>
<b>NorComp</b>		SCALE: <b>N.T.S.</b>	SHEET <b>1</b> OF <b>2</b>	REV <b>0</b>
		DWG NO. <b>6803W3103LYY1</b>		

DESCRIPTION: 680 SERIES CONTACTS

NOTE:  
POWER CONTACTS COME  
PRE-LOADED INTO INSULATORS

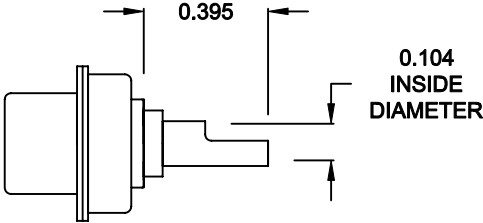

20 AMP POWER CONTACTS  
ACCEPTS UP TO 12 AWG WIRE

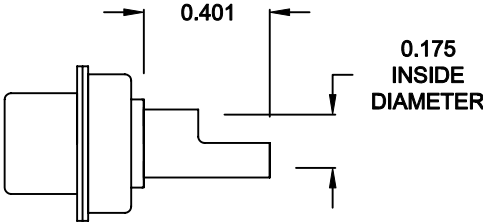

40 AMP POWER CONTACTS  
ACCEPTS UP TO 8 AWG WIRE

RoHS COMPLIANT

	THESE DRAWINGS AND SPECIFICATIONS ARE THE PROPERTY OF NorComp AND SHALL NOT BE REPRODUCED, COPIED OR USED AS THE BASIS FOR THE MANUFACTURE OF SALE OF APPARATUS WITHOUT WRITTEN PERMISSION.	DRAWN: <b>C. SMITH</b>	DATE: <b>09-11-06</b>	
		CHECKED: <b>X</b>	DATE: <b>X</b>	
<h1>NorComp</h1>	SCALE: <b>N.T.S.</b>	SHEET <b>2</b> OF <b>2</b>	REV <b>0</b>	
	DWG NO. <b>6803W3103LYY1</b>			