

DESCRIPTION: POWER - SOLDER CUP - FEMALE - MACHINED

**SPECIFICATIONS:**

**ELECTRICAL:**  
 INSULATOR RESISTANCE: 5 G OHMS Min.  
 DIELECTRIC WITHSTANDING: 1,000 VAC for 1 MINUTE  
 OPERATING TEMPERATURE: -55° C ~ +155° C  
 CONTACT RESISTANCE: 1.0 Milliohms Max.  
 POWER PINS: SEE PART No. BELOW

**MECHANICAL:**  
 CONTACT INSERTION FORCE: 4.5 Kg Max.  
 CONTACT SEPARATOR FORCE: 0.3Kg Min.

**MATERIALS:**  
 CONTACTS: COPPER ALLOY  
 INSULATOR: PBT UL94V-0 RATED, BLK  
 230°C PROCESS TEMP.  
 SHELL: STEEL

**FINISH:**  
 SHELL: NICKEL  
 CONTACTS: FULL GOLD FLASH

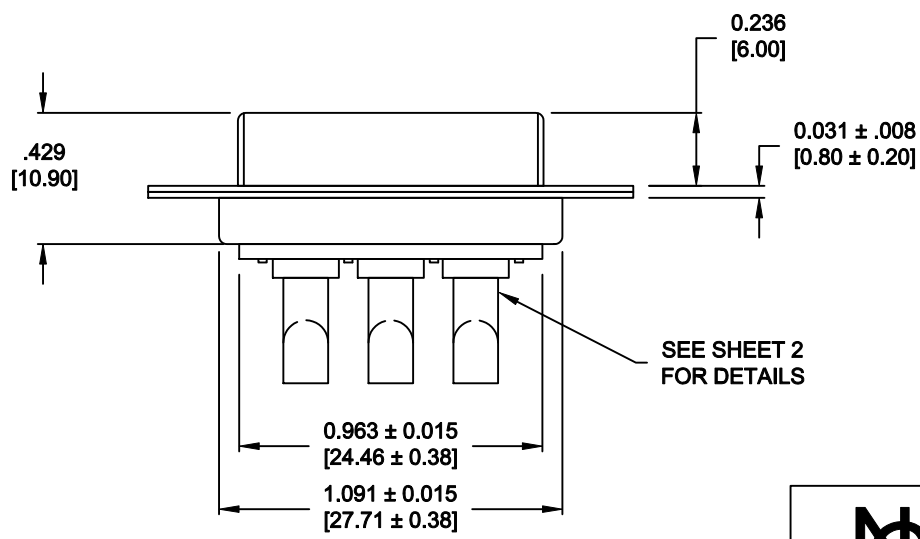
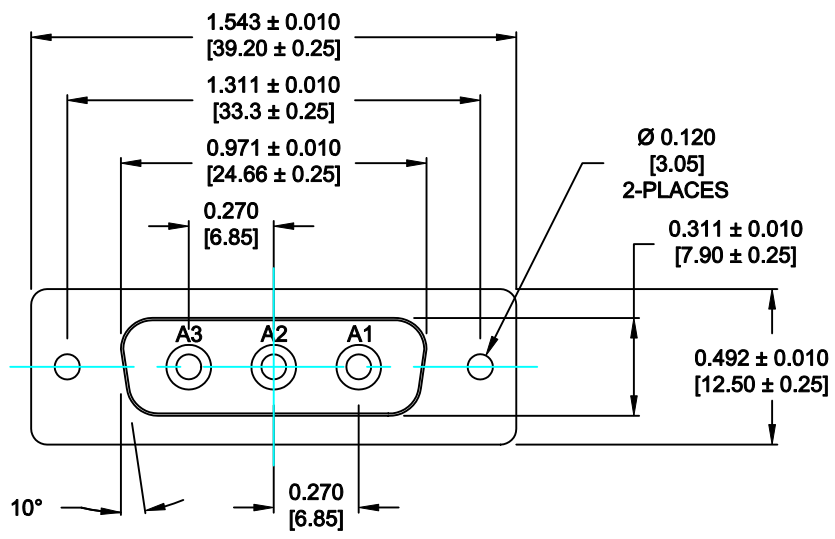

**680M3W3203LYY1**

20 = 20 AMPS  
 40 = 40 AMPS

M = MACHINED CONTACTS

**RoHS COMPLIANT**

	THESE DRAWINGS AND SPECIFICATIONS ARE THE PROPERTY OF NorComp AND SHALL NOT BE REPRODUCED, COPIED OR USED AS THE BASIS FOR THE MANUFACTURE OF SALE OF APPARATUS WITHOUT WRITTEN PERMISSION.		DRAWN: <b>M. SIGMON</b>	DATE: <b>08-20-12</b>
			CHECKED: <b>X</b>	DATE: <b>X</b>
<b>NorComp</b>	SCALE: <b>N.T.S.</b>	SHEET <b>1</b>	OF <b>2</b>	REV <b>0</b>
	DWG NO. <b>680M3W3203LYY1</b>			

**NOTE:  
POWER CONTACTS COME  
PRE-LOADED INTO INSULATORS**

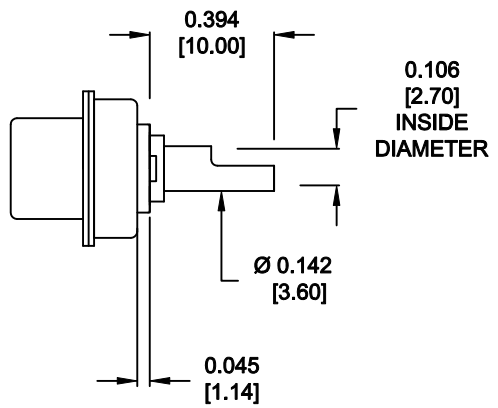

**20 AMP POWER CONTACTS  
ACCEPTS UP TO 12 AWG WIRE**

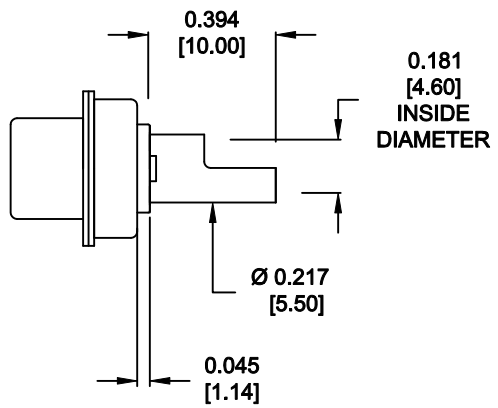

**40 AMP POWER CONTACTS  
ACCEPTS UP TO 8 AWG WIRE**

**RoHS COMPLIANT**

	THESE DRAWINGS AND SPECIFICATIONS ARE THE PROPERTY OF NorComp AND SHALL NOT BE REPRODUCED, COPIED OR USED AS THE BASIS FOR THE MANUFACTURE OF SALE OF APPARATUS WITHOUT WRITTEN PERMISSION.	DRAWN: <b>M. SIGMON</b>		DATE: <b>08-20-12</b>	
		CHECKED: <b>X</b>		DATE: <b>X</b>	
NorComp	SCALE: <b>N.T.S.</b>	SHEET <b>2</b> OF <b>2</b>		REV <b>0</b>	
	DWG NO. <b>680M3W3203LYY1</b>				