

DESCRIPTION: POWER - SOLDER CUP - FEMALE

SPECIFICATIONS:

ELECTRICAL:

INSULATOR RESISTANCE: 5 G OHMS Min.
 DIELECTRIC WITHSTANDING: 1,000 VAC for 1 MINUTE
 OPERATING TEMPERATURE: -55° C ~ +155° C
 CONTACT RESISTANCE: 1 Milliohms Max.
 POWER PINS: SEE PART No. BELOW

MECHANICAL:

CONTACT INSERTION FORCE: 4.5 Kg Max.
 CONTACT SEPARATOR FORCE: 0.3Kg Min.

MATERIALS:

CONTACTS: COPPER ALLOY
 INSULATOR: PBT UL94V-0 RATED, BLK
 230°C PROCESS TEMP.
 SHELL: STEEL
 SEAL: F04 FLEXIBLE ADHESIVE

FINISH:

SHELL: NICKEL
 CONTACTS: FULL GOLD FLASH

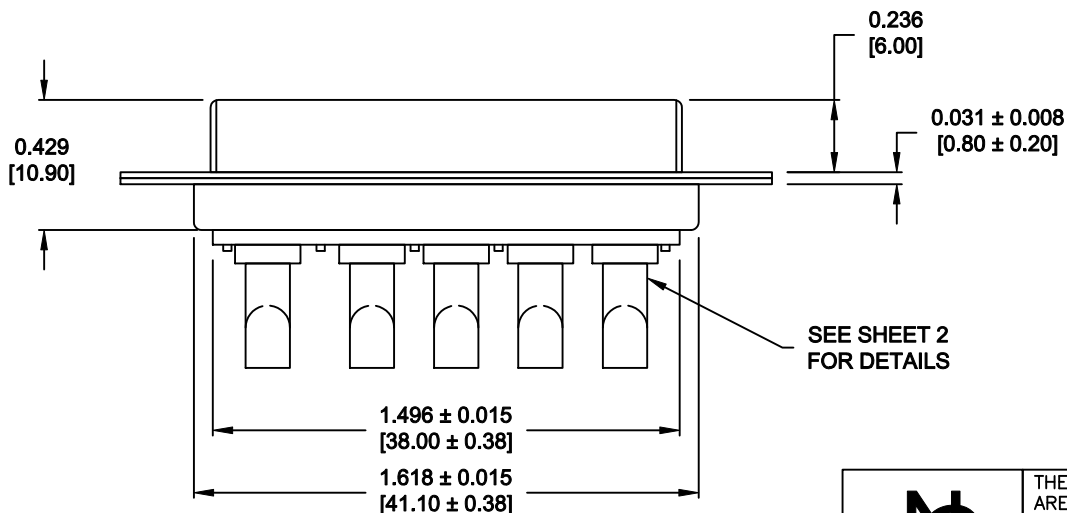
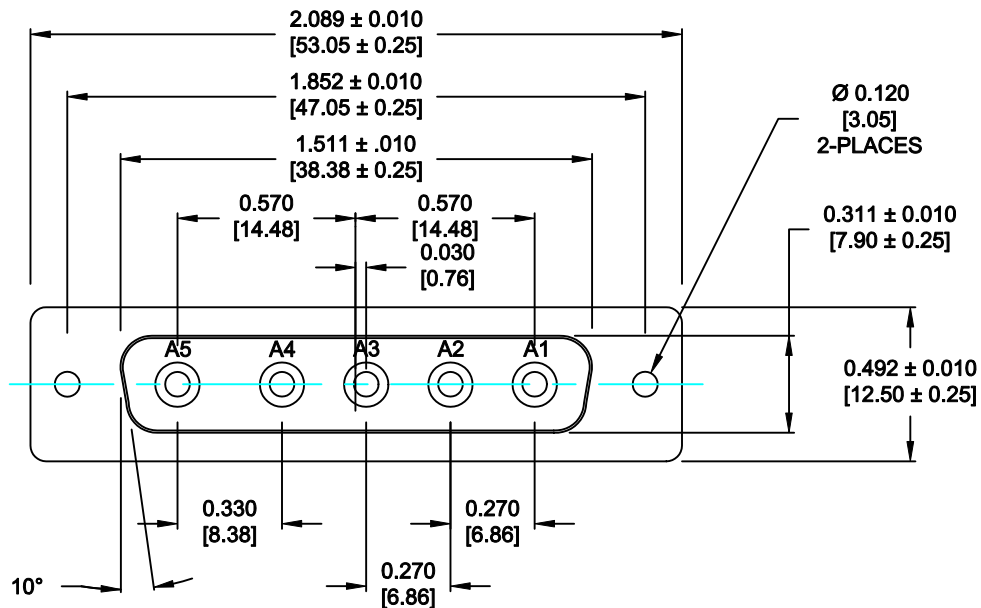



680S5W5203LYY1

20 = 20 AMPS
 40 = 40 AMPS

MEETS IP67 STANDARDS

(SEE PAGE 2 FOR SEALING DETAILS)

RoHS COMPLIANT

	THESE DRAWINGS AND SPECIFICATIONS ARE THE PROPERTY OF NorComp AND SHALL NOT BE REPRODUCED, COPIED OR USED AS THE BASIS FOR THE MANUFACTURE OF SALE OF APPARATUS WITHOUT WRITTEN PERMISSION.		DRAWN: P. JENKINS	DATE: 09-13-11
	CHECKED: X		DATE: X	
		SCALE: N.T.S.	SHEET 1	OF 2
		DWG NO. 680S5W5203LYY1		

DESCRIPTION: 680 SERIES CONTACTS

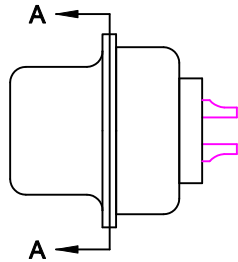

FRONT SEAL APPLIED BETWEEN FRONT INSULATOR AND FRONT METAL SHELL

MIDDLE SEAL APPLIED BETWEEN FRONT INSULATOR AND BACK INSULATOR

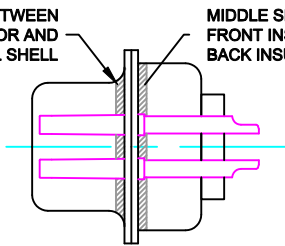

DETAIL A-A

SHOWN FOR REFERENCE ONLY

NOTE: POWER CONTACTS COME PRE-LOADED INTO INSULATORS

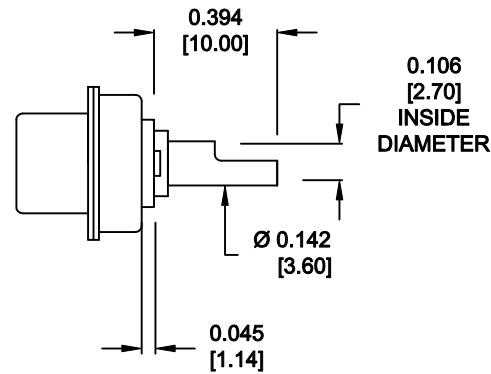

20 AMP POWER CONTACTS
ACCEPTS UP TO 12 AWG WIRE

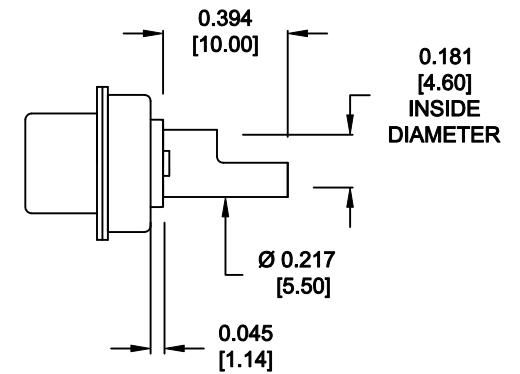

40 AMP POWER CONTACTS
ACCEPTS UP TO 8 AWG WIRE

RoHS COMPLIANT



THESE DRAWINGS AND SPECIFICATIONS ARE THE PROPERTY OF NorComp AND SHALL NOT BE REPRODUCED, COPIED OR USED AS THE BASIS FOR THE MANUFACTURE OF SALE OF APPARATUS WITHOUT WRITTEN PERMISSION.

DRAWN: P. JENKINS		DATE: 09-13-11	
CHECKED: X		DATE: X	
SCALE: N.T.S.	SHEET 2	OF 2	REV 0
DWG NO. 680S5W5203LYY1			

NorComp