

SIGN	DATE	DESCRIPTION	APPROVER
	2007.07.10	Equivalent to previous part number OSTEDXX2150	Sun
THIS IS CAD DRAWING, DO NOT REVISE MANUALLY!!!			

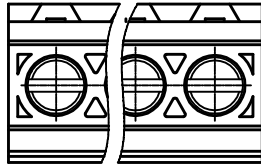

Material

- Terminal body (Contact pin): Brass(Cuzn)
- Terminal screw: Steel Zinc plating: "-slot type
- Contacts: Brass
- Surface of solder tail: Tin plated
- Insulator (housing): Thermoplastic (UL94V-0)

Electrical cULus

- Voltage rating: 300VAC
- Current rating: 8A
- Wire range:
 - Solid wire(AWG): 16-24
 - Stranded wire(AWG):16-24
- Torque(Lb-In): 2.17
- Screw: M2
- Wire strip length: 6-7mm
- Withstanding Voltage: 1.6KV
- Operating temperature: -30°C to +105°C
- Soldering temperature: 250°C±10°C/5 Sec
- Safety Approval: US

RoHS Compliant

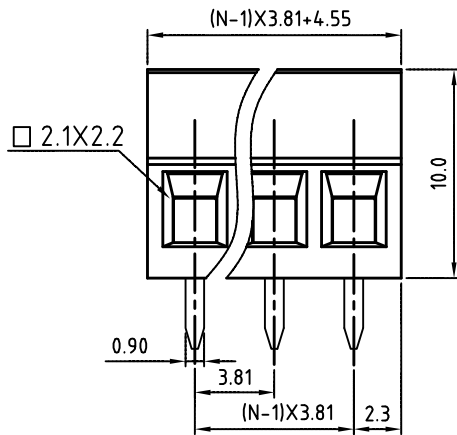

N=Number of positions

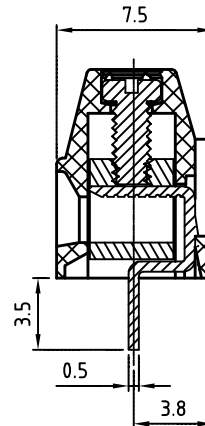

PART NUMBER:

OSTEDXX3150

No. of Poles

02: 2 Poles

03: 3 Poles

: :

24 24Poles

COLOR

0: Black

5: Green (Standard)

6: Blue

8: Grey

P.C.B. LAYOUT

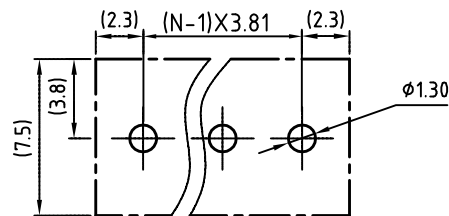

THESE DRAWINGS AND SPECIFICATIONS ARE THE PROPERTY OF ON-SHORE TECHNOLOGY, INC. AND SHALL NOT BE REPRODUCED, COPIED OR USED IN ANY MANNER WITHOUT THE PRIOR WRITTEN CONSENT OF ON-SHORE TECHNOLOGY, INC.



TITLE		OSTED - 3.81mm Series 2p-24p				
PART NO.	OSTEDXX3150	DWG NO.	OSTEDXX3150.DWG			
APPROVED	CHECKED	DESIGNED	DRAWN	CUST NO.	Tolerance	
Shi Jun	Marvin	Marvin	Marvin		UNIT: mm	X. ±0.50
2006.10.20	2006.10.20	2006.10.20	2006.10.20	SHEET: 01/01	SCALE: NONE	X.X ±0.30
				REV: D		X.XX ±0.10
						X° ±1°