

SIGN	DATE	DESCRIPTION	APPROVER
		<i>THIS IS CAD DRAWING, DO NOT REVISE MANUALLY!!!</i>	

- Material:
- Terminal body
  - (Contact pin): Brass
  - Wire guard: Stainless steel
  - Surface of solder tail: Tin plated
  - Insulator(housing): Thermoplastic (UL94V-0)

- Electrical: cULus
- Voltage rating: 300V
  - Current rating: 10A
  - Wire range:
    - Solid wire(AWG): 10-24
    - Stranded wire(AWG): 10-24
  - Wire strip length: 10-11mm
  - Withstanding Voltage: 1.6KV
  - Operating temperature: -30°C to +105°C
  - Soldering temperature: 250°C±10°C/5 Sec
  - Safety Approval: 

RoHS Compliant

PART NUMBER:

**OSTH2XX1080**

- |              |                    |
|--------------|--------------------|
| No. of Poles | COLOR              |
| 02: 2 Poles  | 0: Black           |
| 03: 3 Poles  | 5: Green           |
| ...          | 6: Blue            |
| 12 12 Poles  | 8: Grey (Standard) |

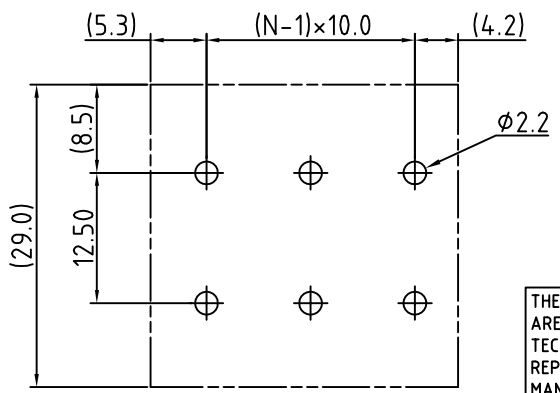
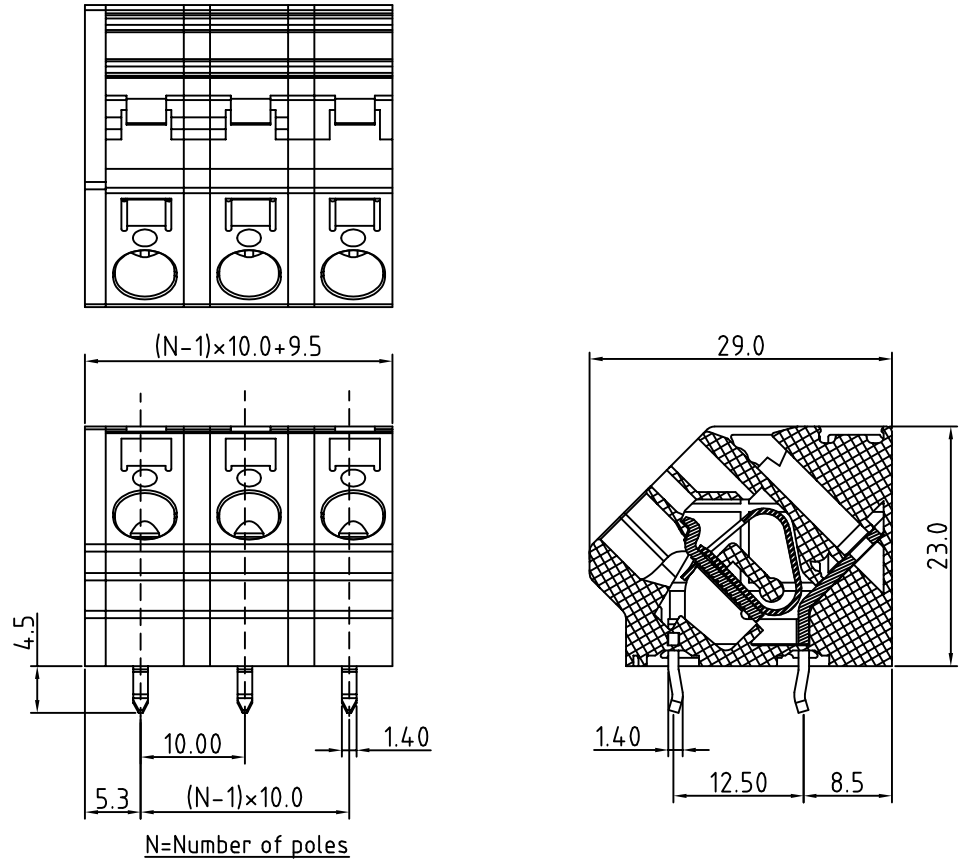

P.C.B. LAYOUT

THESE DRAWINGS AND SPECIFICATIONS ARE THE PROPERTY OF ON-SHORE TECHNOLOGY, INC. AND SHALL NOT BE REPRODUCED, COPIED OR USED IN ANY MANNER WITHOUT THE PRIOR WRITTEN CONSENT OF ON-SHORE TECHNOLOGY, INC.



TITLE		OSTH2 10.0mm series			
PART NO.	OSTH2XX1080	DWG NO.	OSTH2XX1080.DWG		
APPROVED	CHECKED	DESIGNED	DRAWN	CUST NO.	Tolerance
Shi Jun 2006.11.07	Marvin 2006.09.26	Aaron 2006.05.31	Aaron 2006.05.31		X. ±0.50 X.X ±0.30 X.XX ±0.10 X* ±1*
				SHEET: 01/01	REV.: B