

SIGN	DATE	DESCRIPTION	APPROVER
		<i>THIS IS CAD DRAWING, DO NOT REVISE MANUALLY!!!</i>	

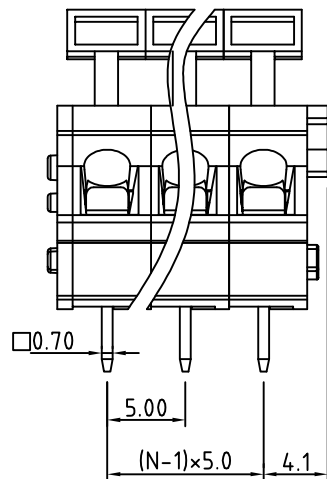

N=Number of poles

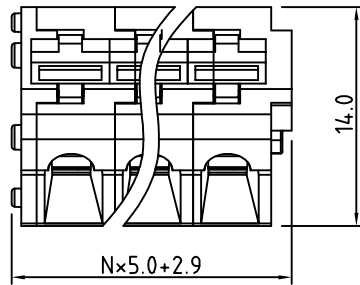
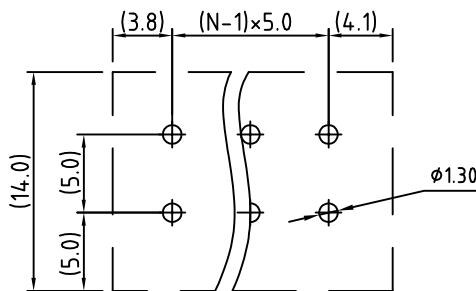
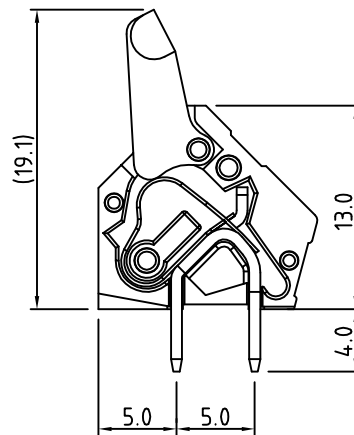

RECOMMENDED PCB LAYOUT

**Material**

- Terminal body(Contact pin) : Brass
- Surface of solder tail : Tin plated
- Wire guard : Stainless steel
- Insulator (housing): Thermoplastic (UL94V-0)

**Electrical**

**cULus**

- Voltage rating: 300V
- Current rating: 15A
- Wire range:
  - Solid wire(AWG): 12-28
  - Stranded wire(AWG): 12-28
- Wire strip length: 6-7mm
- Withstanding Voltage: 1.6KV
- Operating temperature: -30°C to +105°C
- Soldering temperature: 245°C±10°C/5 Sec

RoHS Compliant

PART NUMBER:

**OSTHTXX0080**

No. of Poles:

- 01 1 Pole (basic block)
- 02 2 Poles
- etc. available in 1-24 Poles

COLOR

- 0: Black
- 5: Green
- 6: Blue
- 8: Grey (Standard)

THESE DRAWINGS AND SPECIFICATIONS ARE THE PROPERTY OF ON-SHORE TECHNOLOGY, INC. AND SHALL NOT BE REPRODUCED, COPIED OR USED IN ANY MANNER WITHOUT THE PRIOR WRITTEN CONSENT OF ON-SHORE TECHNOLOGY, INC.



TITLE		OSTHT-5.0 Series				
PART NO.		OSTHTXX0080		DWG NO.		OSTHTXX0080.DWG
APPROVED		CHECKED	DESIGNED	DRAWN	CUST NO.	
			姜開福 2006.01.13	姜開福 2006.01.13		
						Tolerance X. ±0.50 X.X ±0.30 X.XX ±0.10 X° ±1°
				SHEET: 01/01		UNIT: mm SCALE: NONE REV.: C