

SIGN	DATE	DESCRIPTION	APPROVER
<i>THIS IS CAD DRAWING, DO NOT REVISE MANUALLY!!!</i>			

Material

- Terminal body (Contact pin): Brass
- Wire guard: Stainless steel
- Surface of solder tail: Tin plated
- Insulator (housing): Thermoplastic (UL94V-0)

Electrical

- Voltage rating: AC 300V
- Current rating: 10A
- Wire range:
 - Solid wire(AWG): 16-26
 - Stranded wire(AWG): 16-26
- Wire strip length: 7-8mm
- Withstanding Voltage: 1.6KV
- Operating temperature: -40°C to +115°C
- Soldering temperature: 250°C±10°C/5 Sec
- Safety Approval: pending approval 

RoHS Compliant

Part Number

OSTHXXX2281

- | | |
|--------------|--------------------|
| 01: 01 Poles | 0: Black |
| 02: 02 Poles | 2: Red |
| | 5: Green |
| 24: 24 Poles | 8: Grey (Standard) |
| | 9: White |
| | C: Multiple colors |

THESE DRAWINGS AND SPECIFICATIONS ARE THE PROPERTY OF ON-SHORE TECHNOLOGY, INC. AND SHALL NOT BE REPRODUCED, COPIED OR USED IN ANY MANNER WITHOUT THE PRIOR WRITTEN CONSENT OF ON-SHORE TECHNOLOGY, INC.



TITLE		OSTHX 3.5 Series 180° double contact (Wire inlet)			
PART NO.	OSTHXXX2281	DWG NO.	OSTHXXX2281.DWG		
APPROVED	CHECKED	DESIGNED	DRAWN	CUST NO.	Tolerance
		kind 2008.7.22	kind 2008.7.22		X. ±0.50
					X.X ±0.30
					X.XX ±0.10
					X° ±1°
				SHEET: 01/01	REV: B

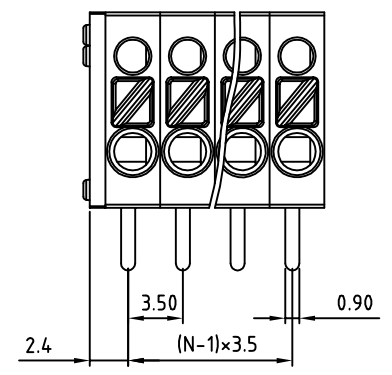
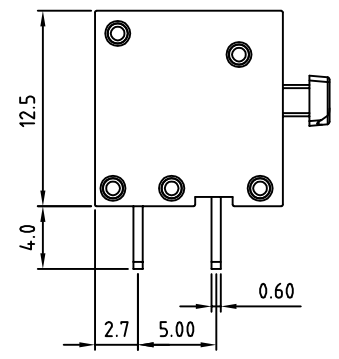
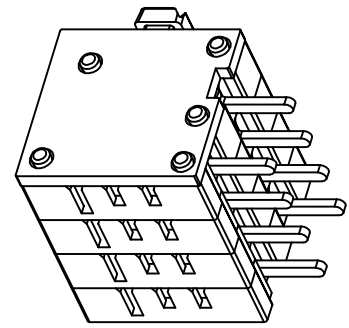
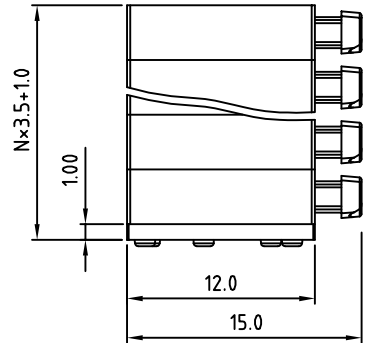

N=Number of poles

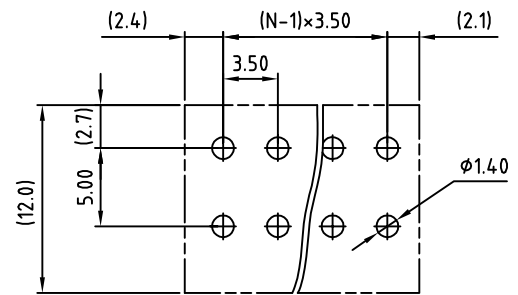

P.C.B LAYOUT