

SIGN	DATE	DESCRIPTION	APPROVER
Δ			

THIS IS CAD DRAWING, DO NOT REVISE MANUALLY!!!

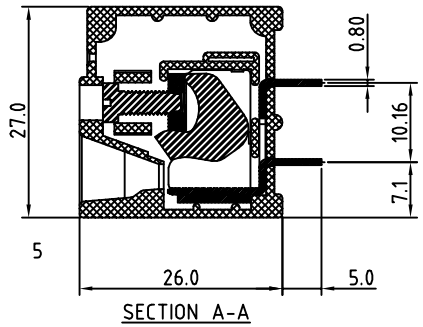
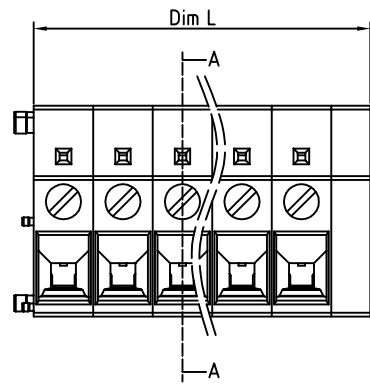
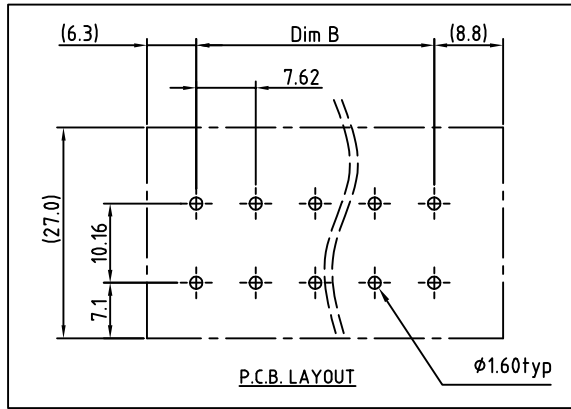
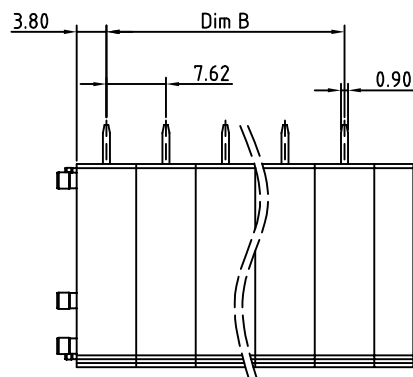

**Material**

- Insulating body Thermoplastic ( UL94V-0 )
- Insulating cover Thermoplastic ( UL94V-0 )
- Terminal screw Steel Zinc plating "-" slot type
- Clampage Steel/steel Zinc plated
- Terminal body Steel, Zinc plating
- Solder pin Brass, Tin plated

**Electrical**

- Voltage rating: 300VAC
- Current rating: 30A
- Wire range:
  - Solid wire(AWG): 10-24
  - Stranded wire(AWG): 10-24
- Torque(Lb-In): 4.3
- Screw: M3
- Wire strip length: 15-16mm
- Withstanding Voltage: 1.6KV
- Operating temperature: -40°C to +115°C
- Soldering temperature: 250°C±10°C/5 Sec

RoHS Compliant

PART NUMBER:

OSTKHXX1550

No. of Poles	COLOR
02 2 Poles	0: Black
03 3 Poles	5: Green (Standard)
...	6: Blue
16 16 Poles	8: Grey

Poles	01	02	03	04	05	06	07	08
Dim L	12.62	20.24	27.86	35.48	43.10	50.72	58.34	65.96
Dim B		7.62	15.24	22.86	30.48	38.10	45.72	53.34
TOL	±0.15				±0.20			
Poles	09	10	11	12	13	14	15	16
Dim L	73.58	81.20	88.82	96.44	104.06	111.68	119.30	126.92
Dim B	60.96	68.58	76.20	83.82	91.44	99.06	106.68	114.30
TOL	±0.25				±0.30			

THESE DRAWINGS AND SPECIFICATIONS ARE THE PROPERTY OF ON-SHORE TECHNOLOGY, INC. AND SHALL NOT BE REPRODUCED, COPIED OR USED IN ANY MANNER WITHOUT THE PRIOR WRITTEN CONSENT OF ON-SHORE TECHNOLOGY, INC.



TITLE		OSTKH 7.62 Series 90D Wire inlet					
PART NO.		OSTKHXX1550		DWG NO.		OSTKHXX1550.DWG	
APPROVED		CHECKED	DESIGNED	DRAWN	CUST NO.		Tolerance
			Aaron 2007.12.04	Aaron 2007.12.04			X. ±0.50
							X.X ±0.30
					SHEET: 01/01		X.XX ±0.10
					REV.: A1		X° ±1°