

SIGN	DATE	DESCRIPTION	APPROVER
		<i>THIS IS CAD DRAWING, DO NOT REVISE MANUALLY!!!</i>	

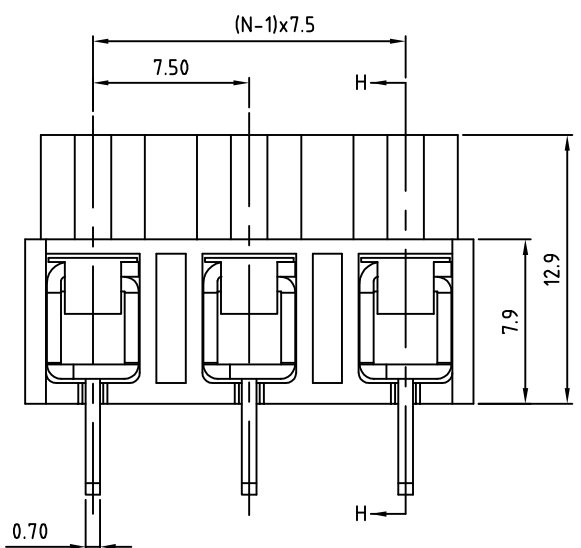

N=Number of poles

P.C.B LAYOUT

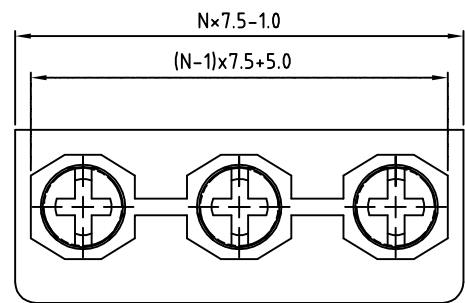
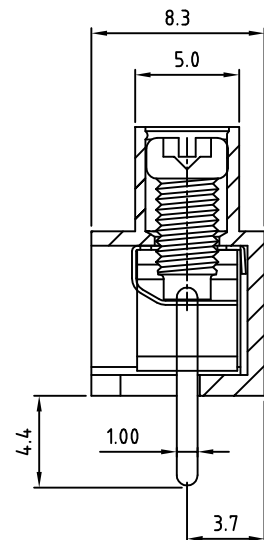
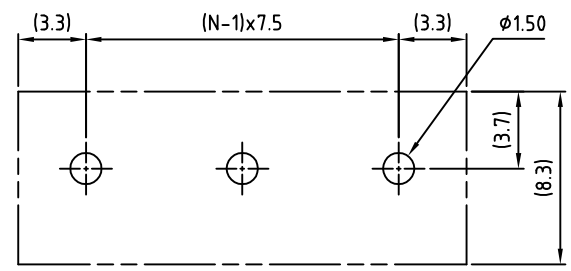

SECTION H-H

Material

- Terminal body
- (metal housing): Brass Stamped
- Terminal screw: Steel Zinc plating "+/-" slot type
- Wire guard: Stainless steel
- Surface of solder tail: Tin plated
- Insulator (housing): Thermoplastic (UL94V-0)

Electrical cULus/VDE

- Voltage rating: 300VAC/450VAC
 - Current rating: 10A/17.5A
 - Wire range: 0.75-1.5mm²
 - Solid wire(AWG): 12-20
 - Stranded wire(AWG): 12-20
 - Torque: 3.5Lb-In/0.4Nm
 - Screw: M3
 - Wire strip length: 6-7mm
 - Withstanding Voltage: 1.6KV/2.5KV
 - Operating temperature: -30°C to +105°C
 - Soldering temperature: 250°C±10°C/5 Sec
 - Safety Approval: (cULus) ⚠ PENDING
- RoHS Compliant

PART NUMBER:

OSTT4XX2450

- No. of Poles
 - 02: 2 Poles
 - 03: 3 Poles
 -
 - 16: 16 Poles
- 5 Green

THESE DRAWINGS AND SPECIFICATIONS ARE THE PROPERTY OF ON-SHORE TECHNOLOGY, INC. AND SHALL NOT BE REPRODUCED, COPIED OR USED IN ANY MANNER WITHOUT THE PRIOR WRITTEN CONSENT OF ON-SHORE TECHNOLOGY, INC.



TITLE		OSTT4-7.5mm 2p-16p		DWG NO.		OSTT4XX2450.DWG	
PART NO.		OSTT4XX2450		CUST NO.			
APPROVED	CHECKED	DESIGNED	DRAWN				
Shi Jun 2006.10.19	Shi Jun 2006.10.19	xionghaitao 2006.10.19	xionghaitao 2006.10.19				
				UNIT: mm		Tolerance	
				SCALE: NONE		X.X ±0.50	
				SHEET: 01/01		X.XX ±0.30	
				REV: D		X° ±0.10	
						X° ±1°	