

SIGN	DATE	DESCRIPTION	APPROVER
		<i>THIS IS CAD DRAWING, DO NOT REVISE MANUALLY!!!</i>	

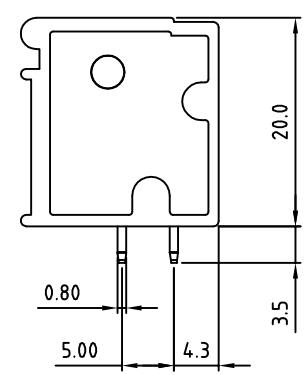

N=Number of poles

P.C.B LAYOUT

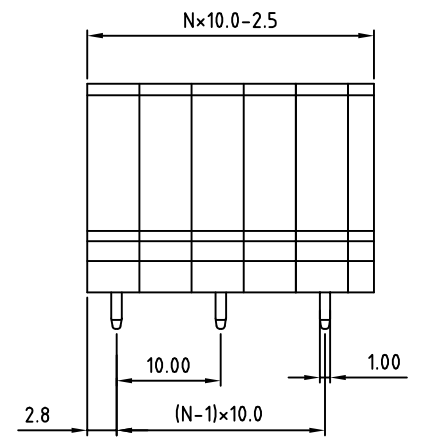
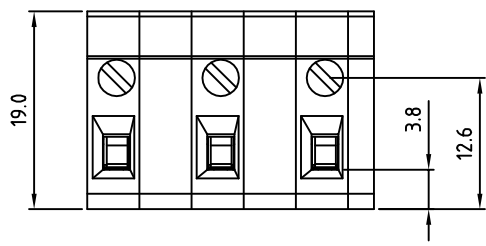
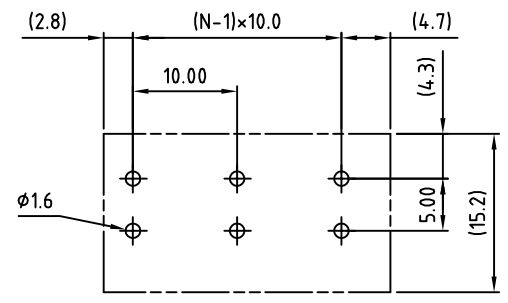

Material

- Terminal body (metal housing): steel stamped
- Terminal screw: Steel Zinc plating "--" slot type
- Contacts: Brass
- Surface of solder tail: Tin plated
- Insulator (housing): Thermoplastic (UL94V-0)

Electrical cULus

- Voltage rating: 300VAC
- Current rating: 20A
- Wire range: Solid wire(AWG): 12-22 Stranded wire(AWG): 12-22
- Torque(Lb-In): 2.4
- Screw: M2.5
- Wire strip length: 10-11mm
- Withstanding Voltage: 1.6KV
- Operating temperature: -30°C to +105°C
- Soldering temperature: 250°C±10°C/5 Sec
- Safety Approval: cULus

RoHS Compliant

PART NUMBER:

OSTTRXX1550

No. of Poles	COLOR
02: 2 Poles	0: Black
03 3 Poles	5: Green (Standard)
... ..	6: Blue
12 12 Poles	8: Grey



THESE DRAWINGS AND SPECIFICATIONS ARE THE PROPERTY OF ON-SHORE TECHNOLOGY, INC. AND SHALL NOT BE REPRODUCED, COPIED OR USED IN ANY MANNER WITHOUT THE PRIOR WRITTEN CONSENT OF ON-SHORE TECHNOLOGY, INC.

TITLE		OSTTR 10.0mm Series vertical (90D wire inlet) 2p-12p			
PART NO.	OSTTRXX1550	DWG NO.	OSTTRXX1550.DWG		
APPROVED	CHECKED	DESIGNED	DRAWN	CUST NO.	Tolerance
Shi Jun 2006.10.20	Shi Jun 2006.10.20	xionghaitao 2006.10.20	xionghaitao 2006.10.20		X. ±0.50 X.X ±0.30 X.XX ±0.10 X° ±1°
				SHEET: 01/01	UNIT: mm SCALE: NONE REV.: E