

SIGN	DATE	DESCRIPTION	APPROVER
THIS IS CAD DRAWING, DO NOT REVISE MANUALLY!!!			

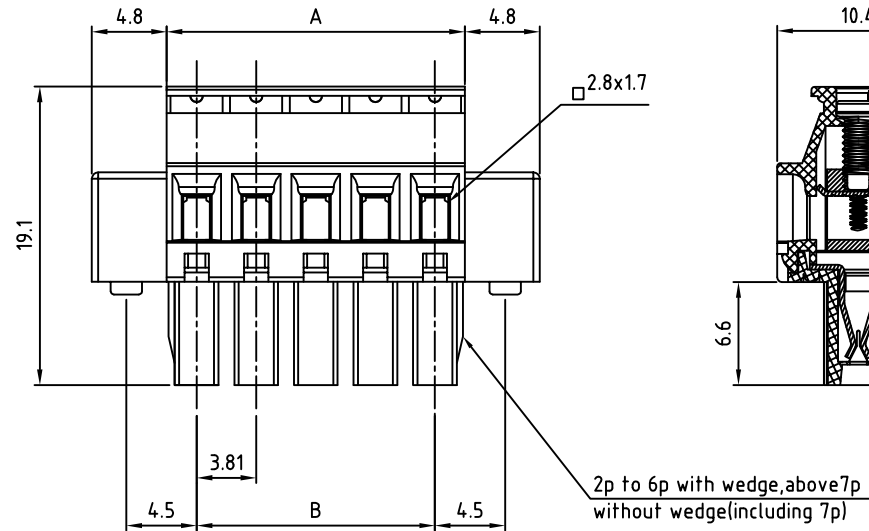
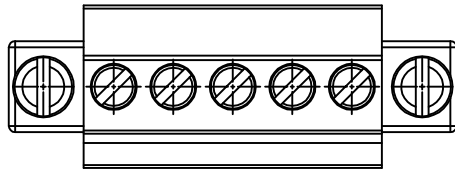

Material

- Terminal body (metal housing): Brass(CuZn)
- Terminal screw: Steel Zinc plating "-" slot type
- With flange screw : steel M2.5
- Wire guard: PhBz Tin plated
- Insulator (housing): Thermoplastic (UL94V-0)

Electrical cULus/VDE

- Voltage rating: 300V/300V
- Current rating: 8A /10A
- Wire range: 1.5mm²
Solid wire(AWG): 16-28
Stranded wire(AWG): 16-28
- Torque: 1.7Lb-In / 0.2N.m
- Screw: M2
- Wire strip length: 6-7mm
- Withstanding Voltage: 1.6KV / 2.5KV
- Operating temperature: -30° C to +105° C
- Safety approval: cULus VDE

RoHS Compliant

PART NUMBER:

OSTTSXX315D

No. of Poles	COLOR
02 2 Poles	0: Black
03 3 Poles	5: Green (Standard)
... ..	6: Blue
24 24 Poles	8: Grey

N = Number of poles
DIMENSION

A	NX3.81
B	(N-1)X3.81

THESE DRAWINGS AND SPECIFICATIONS ARE THE PROPERTY OF ON-SHORE TECHNOLOGY, INC. AND SHALL NOT BE REPRODUCED, COPIED OR USED IN ANY MANNER WITHOUT THE PRIOR WRITTEN CONSENT OF ON-SHORE TECHNOLOGY, INC.



TITLE		OSTTS-3.81mm Series With flange (for latch on back side)			
PART NO.	OSTTSXX315D	DWG NO.	OSTTSXX315D.DWG		
APPROVED	CHECKED	DESIGNED	DRAWN	CUST NO.	Tolerance
Shi Jun 2006.10.25	Marvin 2005.10.25	Marvin 2005.10.25	Marvin 2005.10.25		X. ±0.50 X.X ±0.30 X.XX ±0.10 X° ±1°
				SHEET: 01/01	UNIT: mm SCALE: NONE REV.: D