

SIGN	DATE	DESCRIPTION	APPROVER
△			
THIS IS CAD DRAWING, DO NOT REVISE MANUALLY!!!			

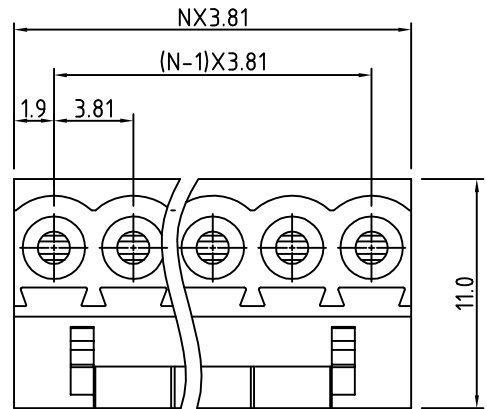

N=Number of poles

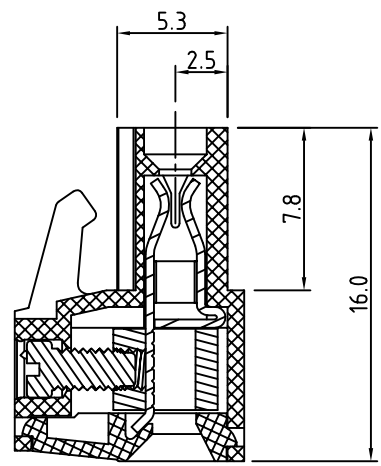
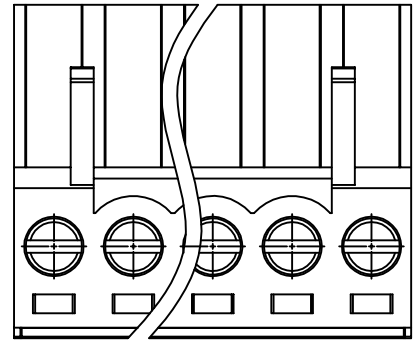

Material

- Terminal body: Brass(CuZn)
- Wire guard : PhBz(CuSn),tin plated
- Terminal screw: Steel Zinc plating"-slot type
- Insulator (housing): Thermoplastic (UL94V-0)

Electrical

- Voltage rating: 300V
- Current rating: 8A
- Wire range:
 - Solid wire(AWG): 16-28
 - Stranded wire(AWG): 16-28
- Torque(Lb-In): 1.7
- Screw: M2
- Wire strip length: 6-7mm
- Withstanding Voltage: 1.6KV
- Operating temperature: -30°C to +105°C
- Safety Approval:

RoHS Compliant

PART NUMBER:

OSTVDXX3150

No. of Poles
 02: 2 Poles
 :
 :
 24: 24 Poles

COLOR
 0: Black
 5: Green (Standard)
 6: Blue
 8: Grey



THESE DRAWINGS AND SPECIFICATIONS ARE THE PROPERTY OF ON-SHORE TECHNOLOGY, INC. AND SHALL NOT BE REPRODUCED, COPIED OR USED IN ANY MANNER WITHOUT THE PRIOR WRITTEN CONSENT OF ON-SHORE TECHNOLOGY, INC.

TITLE		OSTVD-3.81 series 2p-24p			
PART NO.	OSTVDXX3150	DWG NO.	OSTVDXX3150.DWG		
APPROVED	CHECKED	DESIGNED	DRAWN	CUST NO.	Tolerance
Shi Jun 2006.10.23	Shi Jun 2006.10.23	Shi Jun 2006.01.18	Shi Jun 2006.01.18		X. ±0.50 X.X ±0.30 X.XX ±0.10 X° ±1°
				SHEET: 01/01	REV: C