

SIGN	DATE	DESCRIPTION	APPROVER
THIS IS CAD DRAWING, DO NOT REVISE MANUALLY!!!			

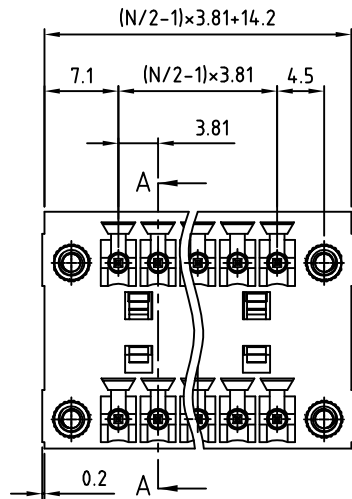

N=Number of poles

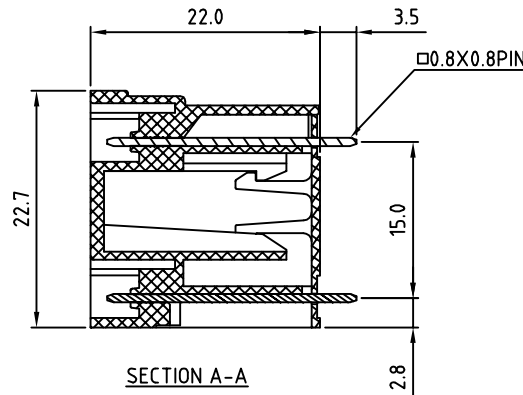

Material

- Terminal body (Contact pin): Brass Whit Tin plated
- With flange nut : Brass
- Insulator (housing): Thermoplastic (UL94V-0)

Electrical cULus

- Voltage rating: 300VAC
- Current rating: 10A
- Withstanding Voltage: 1.6KV
- Operating temperature: -30°C to +105°C
- Soldering temperature: 250°C±10°C/5 Sec
- Safety Approval: US

RoHS Compliant

PART NUMBER:

OSTVLXX3250

- | | |
|----------------|---------------------|
| No. of Poles | COLOR |
| 04: 2x02 Poles | 0: Black |
| 06: 2x03 Poles | 5: Green (Standard) |
| : : | 6: Blue |
| 48 2x24 Poles | 8: Grey |

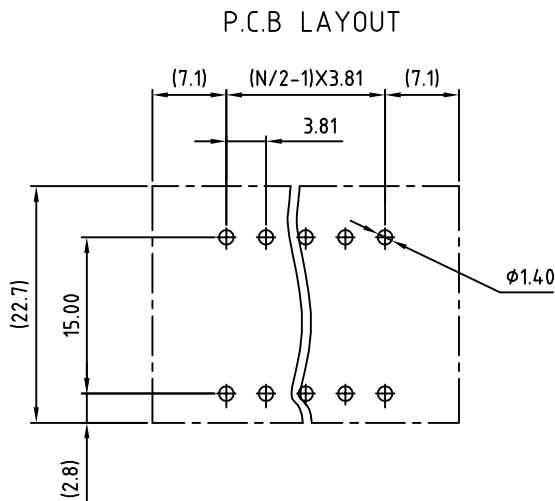

THESE DRAWINGS AND SPECIFICATIONS ARE THE PROPERTY OF ON-SHORE TECHNOLOGY, INC. AND SHALL NOT BE REPRODUCED, COPIED OR USED IN ANY MANNER WITHOUT THE PRIOR WRITTEN CONSENT OF ON-SHORE TECHNOLOGY, INC.



TITLE		OSTVL-3.81mm Series with flange vertical 2x2p-2x24p					
PART NO.	OSTVLXX3250	DWG NO.	OSTVLXX3250.DWG				
APPROVED	CHECKED	DESIGNED	DRAWN	CUST NO.	Tolerance		
Shi Jun 2006.10.23	Marvin 2006.10.23	Marvin 2006.10.23	Marvin 2006.10.23		UNIT: mm	X. ±0.50	
					SCALE: NONE	X.X ±0.30	
				SHEET: 01/01	REV: C	X.XX ±0.10	
						X° ±1°	