

SIGN	DATE	DESCRIPTION	APPROVER
THIS IS CAD DRAWING, DO NOT REVISE MANUALLY!!!			

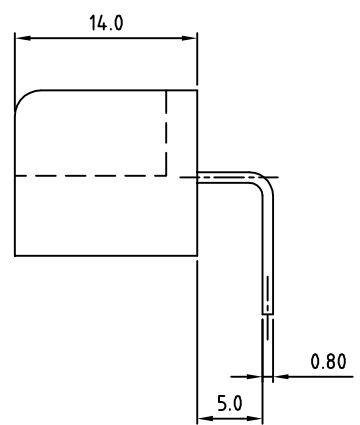
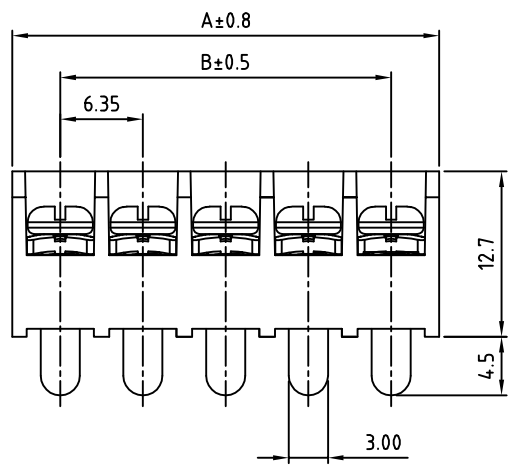
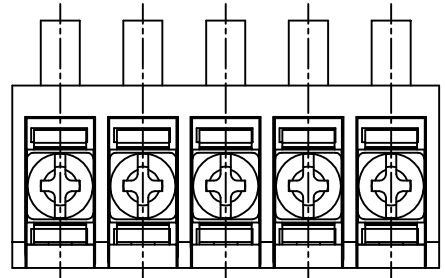

SPECIFICATIONS

VOLTAGE & CURRENT: 250 V, 10 A
 WITHSTANDING VOLTAGE: AC 2000 V/Min
 INSULATION RESISTANCE: 1000 MΩ OR MORE AT DC 500 V
 TEMPERATURE RANGE: -40 °C ~ +105 °C
 SCREW TORQUE VALUE: 5.3 Lb-in.
 WIRE RANGE: 22 - 18 AWG
 1) MOLDED PARTS: POLYIMIDE 66, UL 94 V-0 BLACK
 2) TERMINAL: BRASS, 0.8t, Tin PLATED
 3) TERMINAL SCREWS: STEEL, Ni PLATED, M3
 APPROVAL: US

RoHS Compliant

PART NUMBER:
OSTYK224XX030

No. of Poles
 02: 2 Poles
 03: 3 Poles
 04: 4 Poles
 ⋮
 30: 30 Poles

THESE DRAWINGS AND SPECIFICATIONS ARE THE PROPERTY OF ON-SHORE TECHNOLOGY, INC. AND SHALL NOT BE REPRODUCED, COPIED OR USED IN ANY MANNER WITHOUT THE PRIOR WRITTEN CONSENT OF ON-SHORE TECHNOLOGY, INC.

POLE	1	2	3	4	5	6	7	8	9	10	11	12	13	14	15	16
A		13.70	20.05	26.40	32.75	39.10	45.45	51.80	58.15	64.50	70.85	77.20	83.55	89.90	96.25	102.60
B		6.35	12.70	19.05	25.40	31.75	38.10	44.45	50.80	57.15	63.50	69.85	76.20	82.55	88.90	95.26
POLE	17	18	19	20	21	22	23	24	25	26	27	28	29	30	31	32
A	108.95	115.30	121.65	128.00	134.35	140.70	147.05	153.40	159.75	166.10	172.45	178.80	185.15	191.50	197.85	
B	101.60	107.95	114.30	120.65	127.00	133.35	139.70	146.05	152.40	158.75	165.10	171.45	177.80	184.15	191.00	



TITLE	OSTYK-224 Series						
PART NO.	OSTYK224XX030			DWG NO.	OSTYK224XX030.DWG		
APPROVED	CHECKED	DESIGNED	DRAWN	CUST NO.	Tolerance		
Shi Jun 2006.10.26	Seamus 2006.10.25	Shi Jun 2006.08.10	Seamus 2006.08.10		UNIT: mm	X.	±0.50
					SCALE: NONE	X.X	±0.30
				SHEET: 01/01	REV.: C	X.XX	±0.10
						X°	±1°