

SIGN	DATE	DESCRIPTION	APPROVER
THIS IS CAD DRAWING, DO NOT REVISE MANUALLY!!!			

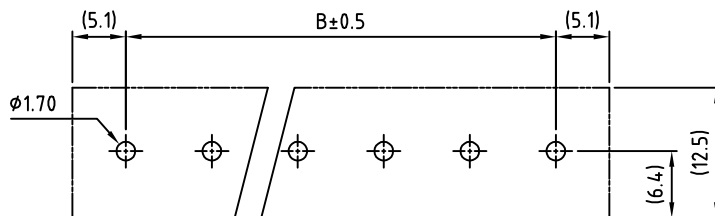
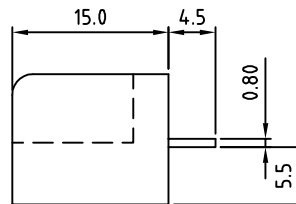
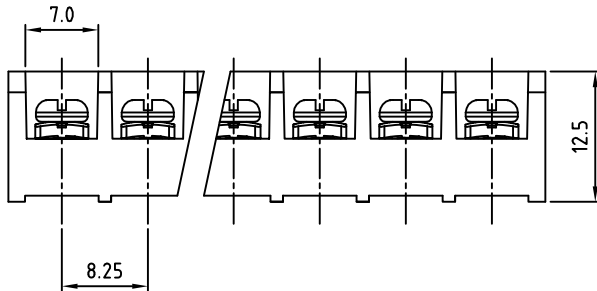
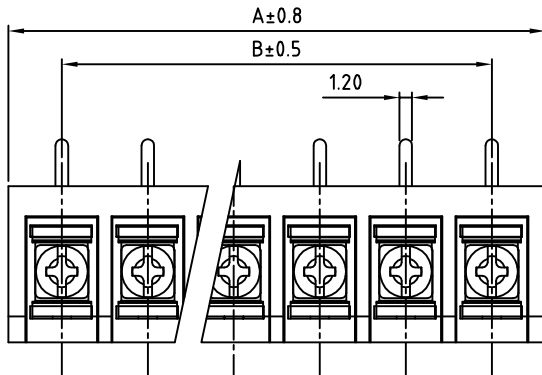

PCB Layout

POLE	1	2	3	4	5	6	7	8	9	10	11	12	13	14	15	16
A	18.50	26.75	35.00	43.25	51.50	59.75	68.00	76.25	84.50	92.75	101.00	109.25	117.50	125.75	134.00	
B	8.25	16.50	24.75	33.00	41.25	49.50	57.75	66.00	74.25	82.50	90.75	99.00	107.25	115.50	123.75	
POLE	17	18	19	20	21	22	23	24	25	26	27	28	29	30	31	32
A	142.25	150.50	158.75	167.00	175.25	183.50	191.75	200.00	208.25	216.50	224.75	233.00	241.25	249.50	257.75	266.00
B	132.00	140.25	148.50	156.75	165.00	173.25	181.50	189.75	198.00	206.25	214.50	222.75	231.00	239.25	247.50	255.75

SPECIFICATIONS

- VOLTAGE & CURRENT: 300V, 20A  
 WITHSTANDING VOLTAGE: AC 2000 V/Min  
 INSULATION RESISTANCE: 1000 MΩ OR MORE AT DC 500 V  
 TEMPERATURE RANGE: -40 °C ~ +105 °C  
 SCREW TORQUE VALUE: 8.8 Lb-In.  
 WIRE RANGE: 22 - 12 AWG  
 1) MOLDED PARTS: POLYIMIDE 66, UL 94 V-0 BLACK  
 2) TERMINAL: BRASS, 0.8t, Tin PLATED  
 3) TERMINAL SCREWS: STEEL, Ni PLATED, M3  
 APPROVAL: US

RoHS Compliant

PART NUMBER:

OSTYK332XX030

- No. of Poles  
 02: 2 Poles  
 03: 3 Poles  
 04: 4 Poles  
 ...  
 30: 30 Poles



TITLE		OSTYK-332 W/O Flange Series			
PART NO.	OSTYK332XX030	DWG NO.	OSTYK332XX030.DWG		
APPROVED	CHECKED	DESIGNED	DRAWN	CUST NO.	Tolerance
Shi Jun 2006.10.26	Seamus 2006.10.25	Steady 2006.10.20	Steady 2006.10.20		X. ±0.50 X.X ±0.30 X.XX ±0.10 X° ±1°
				SHEET: 01/01	REV: C

THESE DRAWINGS AND SPECIFICATIONS ARE THE PROPERTY OF ON-SHORE TECHNOLOGY, INC. AND SHALL NOT BE REPRODUCED, COPIED OR USED IN ANY MANNER WITHOUT THE PRIOR WRITTEN CONSENT OF ON-SHORE TECHNOLOGY, INC.