

SIGN	DATE	DESCRIPTION	APPROVER

THIS IS CAD DRAWING, DO NOT REVISE MANUALLY!!!

SPECIFICATIONS

VOLTAGE & CURRENT:	300 V, 20A
WITHSTANDING VOLTAGE:	AC 2000 V/Min
INSULATION RESISTANCE:	1000 MΩ OR MORE AT DC 500 V
TEMPERATURE RANGE:	-40 °C ~ +105 °C
SCREW TORQUE VALUE:	8.8 Lb-in.
WIRE RANGE:	22 - 12 AWG
1) MOLDED PARTS:	THERMOPLASTIC, UL 94 V-0 BLACK
2) TERMINAL:	BRASS, 0.8t, Tin PLATED
3) TERMINAL SCREWS:	STEEL, Ni PLATED, M3

APPROVAL: 

RoHS Compliant

PART NUMBER:

OSTYK333XX030

NO. OF POLES

- 02: 2 POLES
- 03: 3 POLES
- 04: 4 POLES
- ...
- 30: 30 POLES

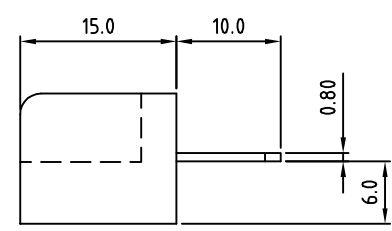
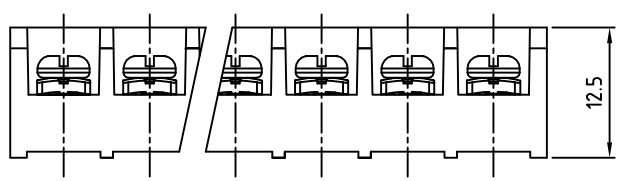
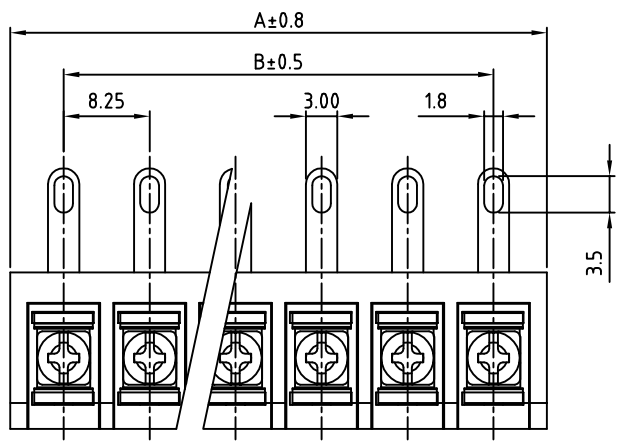

POLE	1	2	3	4	5	6	7	8	9	10	11	12	13	14	15	16
A		18.50	26.75	35.00	43.25	51.50	59.75	68.00	76.25	84.50	92.75	101.00	109.25	117.50	125.75	134.00
B		8.25	16.50	24.75	33.00	41.25	49.50	57.75	66.00	74.25	82.50	90.75	99.00	107.25	115.50	123.75
POLE	17	18	19	20	21	22	23	24	25	26	27	28	29	30		
A	142.25	150.50	158.75	167.00	175.25	183.50	191.75	200.00	208.25	216.50	224.75	233.00	241.25	249.50		
B	132.00	140.25	148.50	156.75	165.00	173.25	181.50	189.75	198.00	206.25	214.50	222.75	231.00	239.25		

THESE DRAWINGS AND SPECIFICATIONS ARE THE PROPERTY OF ON-SHORE TECHNOLOGY, INC. AND SHALL NOT BE REPRODUCED, COPIED OR USED IN ANY MANNER WITHOUT THE PRIOR WRITTEN CONSENT OF ON-SHORE TECHNOLOGY, INC.



TITLE		OSTYK-333 Series			
PART NO.		OSTYK333XX030		DWG NO.	OSTYK333XX030.DWG
APPROVED	CHECKED	DESIGNED	DRAWN	CUST NO.	Tolerance
Shi Jun 2007.07.18	Seamus 2007.07.18	LUCY 2007.7.18	LUCY 2007.7.18		X. ±0.50
				UNIT: mm	X.X ±0.30
				SCALE: NONE	X.XX ±0.10
				SHEET: 01/01	X° ±1°
				REV.: B	