

SIGN	DATE	DESCRIPTION	APPROVER

THIS IS CAD DRAWING, DO NOT REVISE MANUALLY!!!

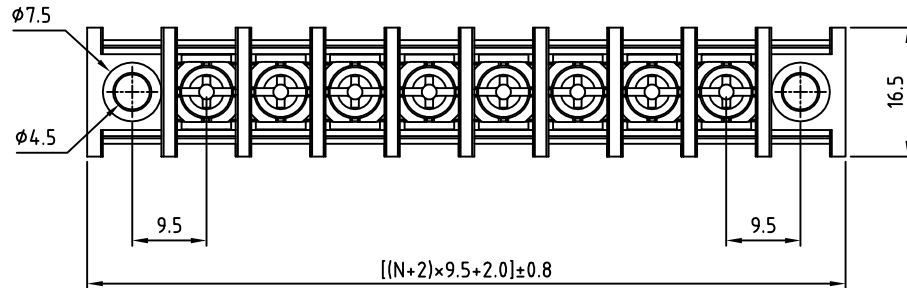

SPECIFICATIONS

VOLTAGE & CURRENT:	300 V, 25 A
WITHSTANDING VOLTAGE:	AC 2000 V/Min
INSULATION RESISTANCE:	1000 MΩ OR MORE AT DC 500 V
TEMPERATURE RANGE:	-40 °C ~ +105 °C
SCREW TORQUE VALUE:	8.8 Lb-in.
WIRE RANGE:	22 - 12 AWG
1) MOLDED PARTS:	THERMOPLASTIC, UL 94 V-0 BLACK
2) TERMINAL:	BRASS, 0.8t, Tin PLATED
3) TERMINAL SCREWS:	STEEL, Ni PLATED, M3.5

APPROVAL:

RoHS Compliant

PART NUMBER:

OSTYK512XX330

NO. OF POLES

- 02: 2 POLES
- 03: 3 POLES
- 04: 4 POLES

30: 30 POLES

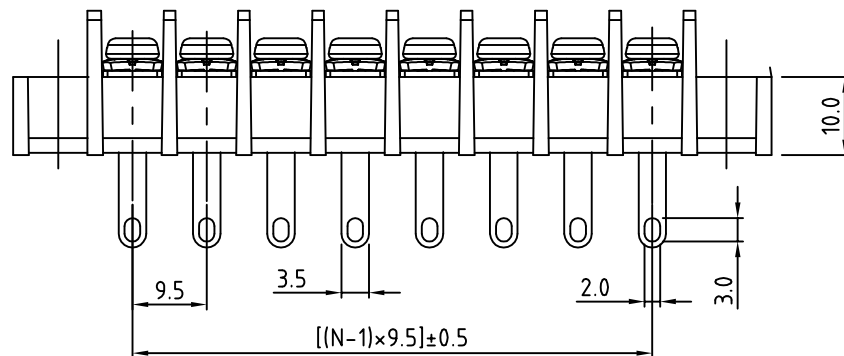

ON-SHORE TECHNOLOGY, INC.

THESE DRAWINGS AND SPECIFICATIONS ARE THE PROPERTY OF ON-SHORE TECHNOLOGY, INC. AND SHALL NOT BE REPRODUCED, COPIED OR USED IN ANY MANNER WITHOUT THE PRIOR WRITTEN CONSENT OF ON-SHORE TECHNOLOGY, INC.

TITLE		OSTYK-512 W/Flange Series				
PART NO.		OSTYK512XX330			DWG NO.	OSTYK512XX330.DWG
APPROVED	CHECKED	DESIGNED	DRAWN	CUST NO.	Tolerance	
Shi Jun 2007.07.18	Seamus 2007.07.18	LUCY 2007.7.18	LUCY 2007.7.18		UNIT: mm	X. ±0.50
					SCALE: NONE	X.X ±0.30
					SHEET: 01/01	X.XX ±0.10
					REV.: B	X° ±1°