

SIGN	DATE	DESCRIPTION	APPROVER

THIS IS CAD DRAWING, DO NOT REVISE MANUALLY!!!

SPECIFICATIONS

VOLTAGE & CURRENT: 300 V, 30 A
 WITHSTANDING VOLTAGE: AC 2000 V/Min
 INSULATION RESISTANCE: 1000 MΩ OR MORE AT DC 500 V
 TEMPERATURE RANGE: -40 °C ~ +105 °C
 SCREW TORQUE VALUE: 15.8 Lb-In.
 WIRE RANGE: 22 - 12 AWG
 1) MOLDED PARTS: THERMOPLASTIC, UL 94 V-0 BLACK
 2) TERMINAL: BRASS, 0.8t, Tin PLATED
 3) TERMINAL SCREWS: STEEL, Ni PLATED, M4

APPROVAL: 

RoHS Compliant

PART NUMBER:

OSTYK555XX030

NO. OF POLES

- 02: 2 POLES
- 03: 3 POLES
- 04: 4 POLES
- ⋮
- 20: 20 POLES

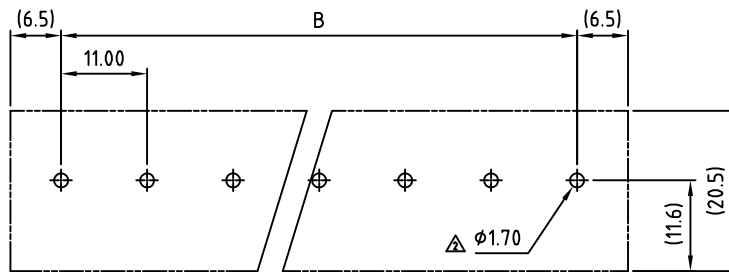
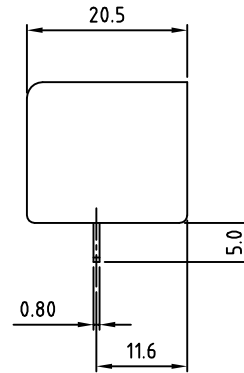
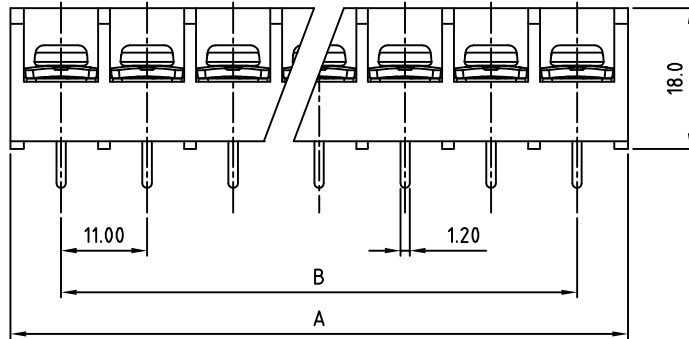
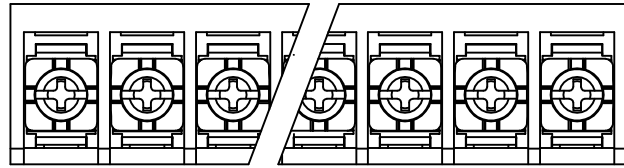

POLE	2	3	4	5	6	7	8	9	10	11	12	13	14	15	16
A	24.00	35.00	46.00	57.00	68.00	79.00	90.00	101.0	112.0	123.0	134.0	145.0	156.0	167.0	178.0
B	11.00	22.00	33.00	44.00	55.00	66.00	77.00	88.00	99.00	110.0	121.0	132.0	143.0	154.0	165.0
TOL	±0.30			±0.40			±0.50								
POLE	17	18	19	20											
A	189.0	200.0	211.0	222.0											
B	176.0	187.0	198.0	209.0											
TOL	±0.60														

THESE DRAWINGS AND SPECIFICATIONS ARE THE PROPERTY OF ON-SHORE TECHNOLOGY, INC. AND SHALL NOT BE REPRODUCED, COPIED OR USED IN ANY MANNER WITHOUT THE PRIOR WRITTEN CONSENT OF ON-SHORE TECHNOLOGY, INC.



TITLE		OSTYK-555 W/O Flange Series			
PART NO.	OSTYK555XX030	DWG NO.	OSTYK555XX030.DWG		
APPROVED	CHECKED	DESIGNED	DRAWN	CUST NO.	Tolerance
Shi Jun 2007.07.18	Seamus 2007.07.18	LUCY 2007.7.18	LUCY 2007.7.18		X. ±0.50 X.X ±0.30 X.XX ±0.10 X° ±1°
SHEET: 01/01				UNIT: mm	SCALE: NONE
				REV.: C	