

SIGN	DATE	DESCRIPTION	APPROVER

THIS IS CAD DRAWING, DO NOT REVISE MANUALLY!!!

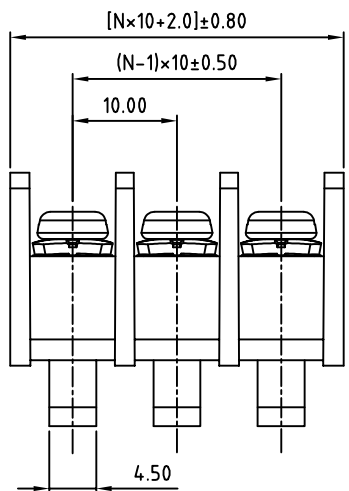

N= Number of poles

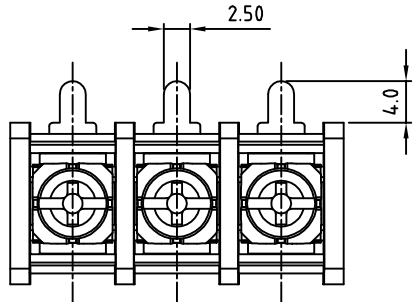
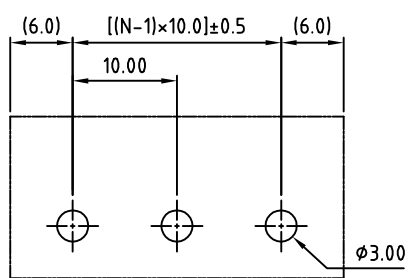

PCB Layout

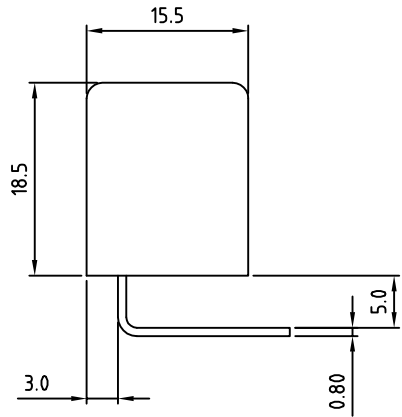

SPECIFICATIONS

VOLTAGE & CURRENT: 300 V, 25 A

WITHSTANDING VOLTAGE: AC 2000 V/Min

INSULATION RESISTANCE: 1000 MΩ OR MORE AT DC 500 V

TEMPERATURE RANGE: -40 °C ±105 °C

SCREW TORQUE VALUE: 8.8 Lb-In.

WIRE RANGE: 22 - 12 AWG

1) MOLDED PARTS: THERMOPLASTIC, UL 94 V-0 BLACK

2) TERMINAL: BRASS, 0.8t, Tin PLATED

3) TERMINAL SCREWS: STEEL, Ni PLATED, M3.5

APPROVAL: RoHS Compliant

PART NUMBER: **OSTYK611XX030**

NO. OF POLES

- 02: 2 POLES
- 03: 3 POLES
- 04: 4 POLES
- ⋮
- 30: 30 POLES



THESE DRAWINGS AND SPECIFICATIONS ARE THE PROPERTY OF ON-SHORE TECHNOLOGY, INC. AND SHALL NOT BE REPRODUCED, COPIED OR USED IN ANY MANNER WITHOUT THE PRIOR WRITTEN CONSENT OF ON-SHORE TECHNOLOGY, INC.

TITLE		OSTYK-611 W/O Flange Series			
PART NO.		OSTYK611XX030		DWG NO.	OSTYK611XX030.DWG
APPROVED	CHECKED	DESIGNED	DRAWN	CUST NO.	Tolerance
Shi Jun 2007.07.18	Seamus 2007.07.18	LUCY 2007.7.18	LUCY 2007.7.18		X. ±0.50
				UNIT: mm	X.X ±0.30
				SCALE: NONE	X.XX ±0.10
				SHEET: 01/01	X° ±1°
				REV.: B	