

N=The number of contacts

P.C.B.LAYAUT

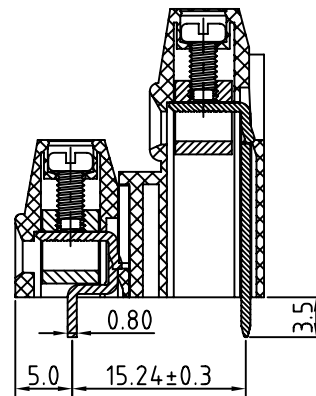
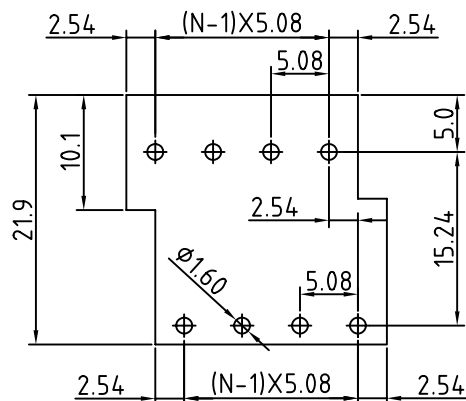

SIGN	DATE	DESCRIPTION	APPROVER
△			
△			
△			

Technical Data:

Material:

- Contact(metal housing): Brass Machined.
- Terminal screw: Steel galvanized and chromitize.
- Solder Pin: Brass with Tin plated
- Insulator body(housing): Polyamide(Glass filled)(UL94V-0)
- Standard Color: Green

Electrical:

- Voltage rating: 300VAC
- Current rating: 10Amps/way max
- Contact resistance: 20mΩ(max)
- Insulation resistance: 5000MΩ/1000V
- Withsanding Voltage: 1500VAC(lmim) Test time=60sec/1pcs
- Wire range: 12-22AWG

Mechanical:

- Torque: 4kg-cm/M2.5
- Operating temperature: -33°C to +120°C
- Soldering ability: 95%coverage(min)
 - Test temperature= 230°C±10°C
 - Test time= 4sec±0.5sec
- Soldring reliability:
 - Test temperature= 250°C±10°C
 - 5 seconds max

THESE DRAWINGS AND SPECIFICATIONS ARE THE PROPERTY OF ON-SHORE TECHNOLOGY, INC. AND SHALL NOT BE REPRODUCED, COPIED OR USED IN ANY MANNER WITHOUT THE PRIOR WRITTEN CONSENT OF ON-SHORE TECHNOLOGY, INC.



PART. NAME: OSTYL 5.08 Series Right				TITLE:	
PART. NO.: OSTYLXX6150 (XX DENOTES NUMBER OF POSITIONS)				DWG NAME: OSTYLXX6150.DWG	
APPROVED BY	CHECKED BY	DESIGNED BY	DRAWN BY	CUSTOM NO.:	Tolerance
		Marvin	Marvin		x. ±0.50
		2004.07.24	2004.07.24		x.x ±0.30
					x.xx ±0.10
					xx² ±1°
				UNITS: mm	
				SCALE: 2/1	
				REVISION: B2	