

SIGN	DATE	DESCRIPTION	APPROVER

THIS IS CAD DRAWING, DO NOT REVISE MANUALLY!!!

Material

- Terminal body
- (metal housing): Brass(CuZn)
- Terminal screw: Steel Zinc plating "-" slot type
- Contacts: Brass
- Surface of solder tail: Tin plated
- Insulator (housing): Thermoplastic (UL94V-0)

Electrical

- Voltage rating: 150VAC
- Current rating: 10A
- Wire range:
 - Solid wire(AWG): 16-24
 - Stranded wire(AWG): 16-24
- Torque(Lb-In): 1.7
- Screw: M2
- Wire strip length: 5-6mm
- Withstanding Voltage: 1.3KV
- Operating temperature: -30°C to +105°C
- Soldering temperature: 250°C±10°C/5 Sec
- Safety Approval: (cULus) pending

RoHS Compliant

PART NUMBER:

OSTYPXX2150

No. of Poles

02: 2 Poles

:

24: 24 Poles

COLOR

0: Black

5: Green (Standard)

6: Blue

8: Grey

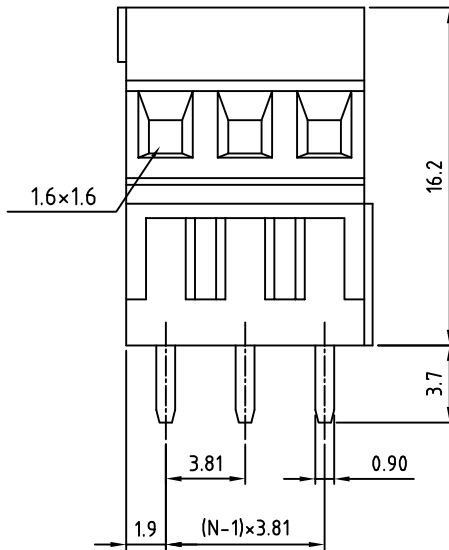
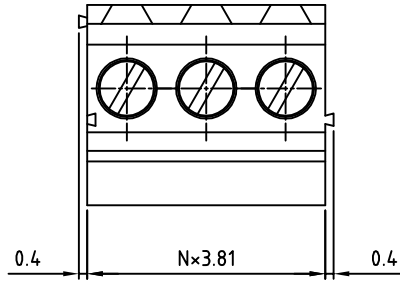

N=Number of poles

P.C.B. LAYOUT

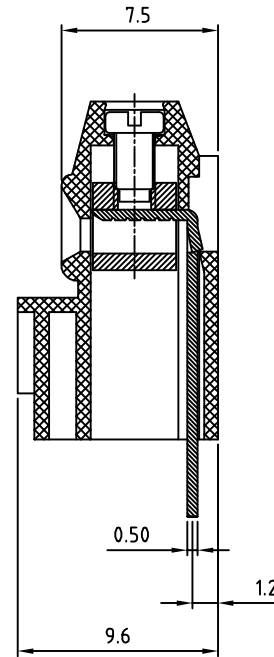
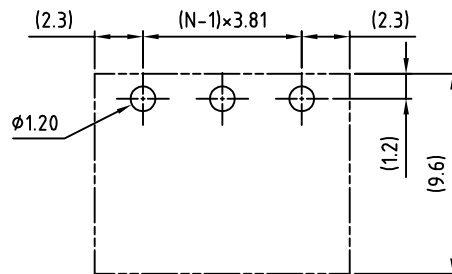

THESE DRAWINGS AND SPECIFICATIONS ARE THE PROPERTY OF ON-SHORE TECHNOLOGY, INC. AND SHALL NOT BE REPRODUCED, COPIED OR USED IN ANY MANNER WITHOUT THE PRIOR WRITTEN CONSENT OF ON-SHORE TECHNOLOGY, INC.



TITLE		OSTYP 3.81mm series solid block 2p-24p			
PART NO.	OSTYPXX2150	DWG NO.	OSTYPXX2150.DWG		
APPROVED	CHECKED	DESIGNED	DRAWN	CUST NO.	Tolerance
Shi Jun 2006.10.20	Shi Jun 2006.10.20	xionghaitao 2006.10.20	xionghaitao 2006.10.20		X. ±0.50
					X.X ±0.30
					X.XX ±0.10
				SHEET: 01/01	X° ±1°