

SIGN	DATE	DESCRIPTION	APPROVER
THIS IS CAD DRAWING, DO NOT REVISE MANUALLY!!!			

**Material**

- Terminal body
- (metal housing): Brass(CuZn)
- Terminal screw: Steel Zinc plating "-" slot type
- Contacts: Brass
- Surface of solder tail: Tin plated
- Insulator (housing): Thermoplastic (UL94V-0)

**Electrical**

- Voltage rating: 150VAC
- Current rating: 10A
- Wire range:  
Solid wire(AWG): 16-24  
Stranded wire(AWG): 16-24
- Torque(Lb-In): 1.7
- Screw: M2
- Wire strip length: 5-6mm
- Withstanding Voltage: 1.3KV
- Operating temperature: -30°C to +105°C
- Soldering temperature: 250°C±10°C/5 Sec
- Safety Approval:  US

RoHS Compliant

**PART NUMBER**

**OSTYQXX6150**

No. of Poles  
04: 4 Poles  
06: 6 Poles  
... ..  
48: 48 Poles

COLOR:  
0: Black  
5: Green (Standard)  
6: Blue  
8: Grey

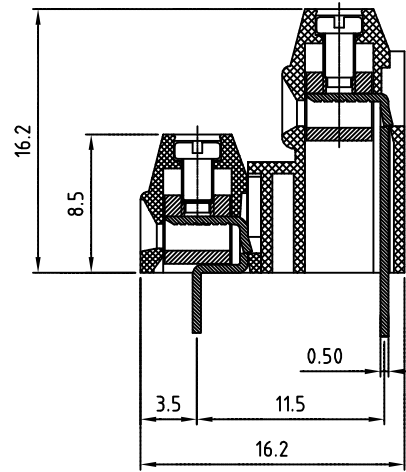
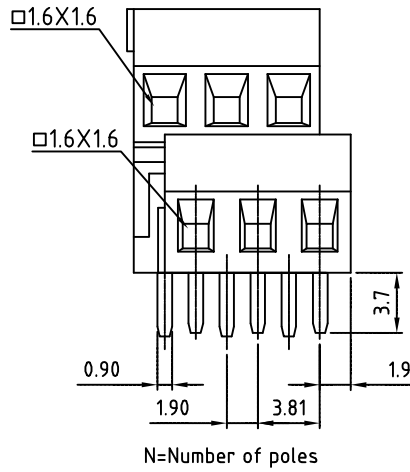
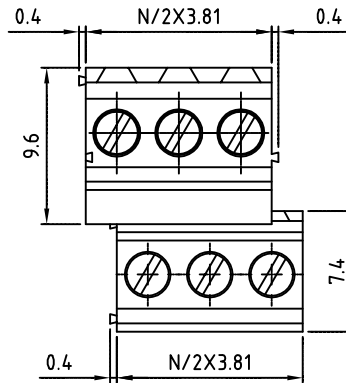

**P.C.B LAYOUT**

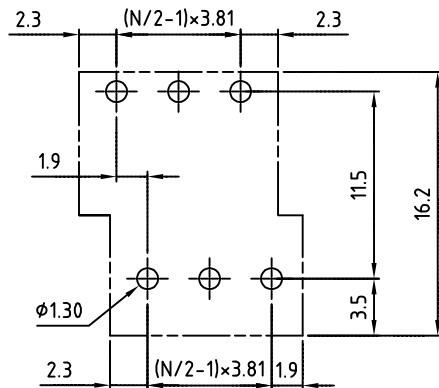

THESE DRAWINGS AND SPECIFICATIONS ARE THE PROPERTY OF ON-SHORE TECHNOLOGY, INC. AND SHALL NOT BE REPRODUCED, COPIED OR USED IN ANY MANNER WITHOUT THE PRIOR WRITTEN CONSENT OF ON-SHORE TECHNOLOGY, INC.



TITLE		OSTYQ-3.81mm series right			
PART NO.	OSTYQXX6150	DWG NO.	OSTYQXX6150.DWG		
APPROVED	CHECKED	DESIGNED	DRAWN	CUST NO.	Tolerance
Shi Jun 2006.10.20	Shi Jun 2006.10.20	xionghaitao 2006.10.20	xionghaitao 2006.10.20		X. ±0.50 X.X ±0.30 X.XX ±0.10 X° ±1°
SHEET: 01/01				UNIT: mm	SCALE: NONE
				REV.: A	