

# SPECIFICATIONS

PARAMETERS	VALUES	UNITS
RESONANT FREQUENCY	2,000 ± 500	Hz
RESONANT IMPEDANCE (MAX)	300	Ohm
MAX INPUT VOLTAGE	30	Vp-p
CAPACITANCE @ 1kHz	45,000 ± 30%	pF
PLATE MATERIAL	BRASS	-
OPERATING TEMPERATURE	-20 ~ +70	°C
STORAGE TEMPERATURE	-30 ~ +80	°C

THIS DOCUMENT CONTAINS DATA PROPRIETARY TO PROJECTS UNLIMITED, INC. ANY USE OR REPRODUCTION, IN ANY FORM, WITHOUT PRIOR WRITTEN PERMISSION OF PROJECTS UNLIMITED, INC. IS PROHIBITED.  
©2003, Projects Unlimited Inc.

# REVISION HISTORY

LTR	DESCRIPTION	DATE	APPROVED
-	RELEASED FROM ENGINEERING	4/9/2002	
A	REVISED TO NEW TEMPLATE	9/4/2003	R.W.
B	REVISED SPECIFICATIONS	1/12/2004	R.W.
C	REVISED DIMENSION SIZE AND SYLE	1/19/2006	B.R.
D	REVISED TO INVENTOR 3-D DRAWING TEMPLATE	8/11/2010	B.R.

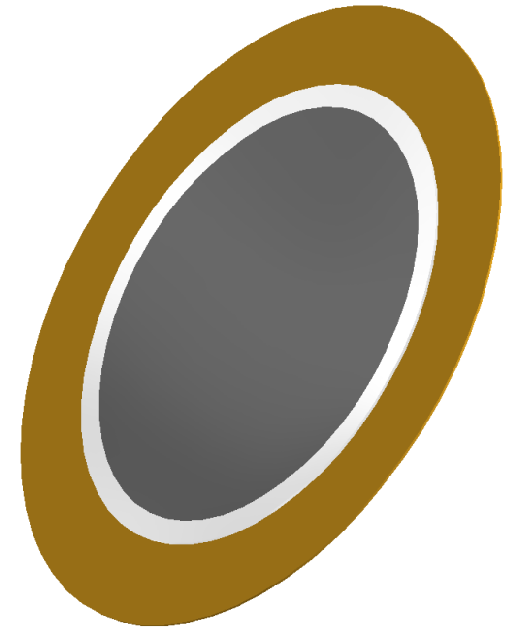
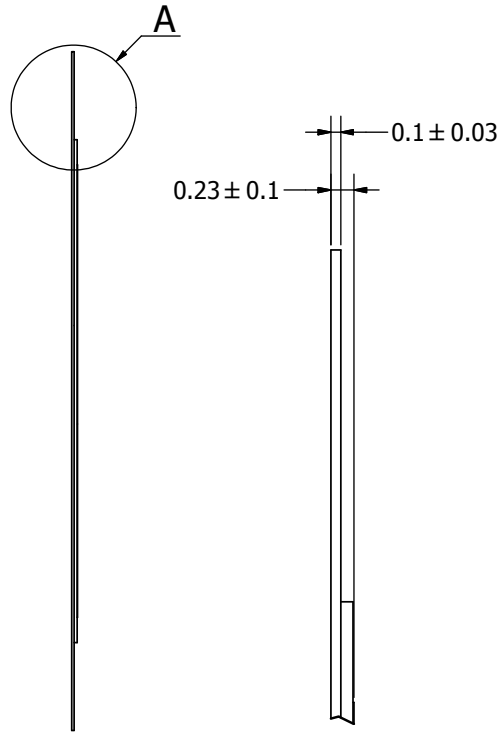
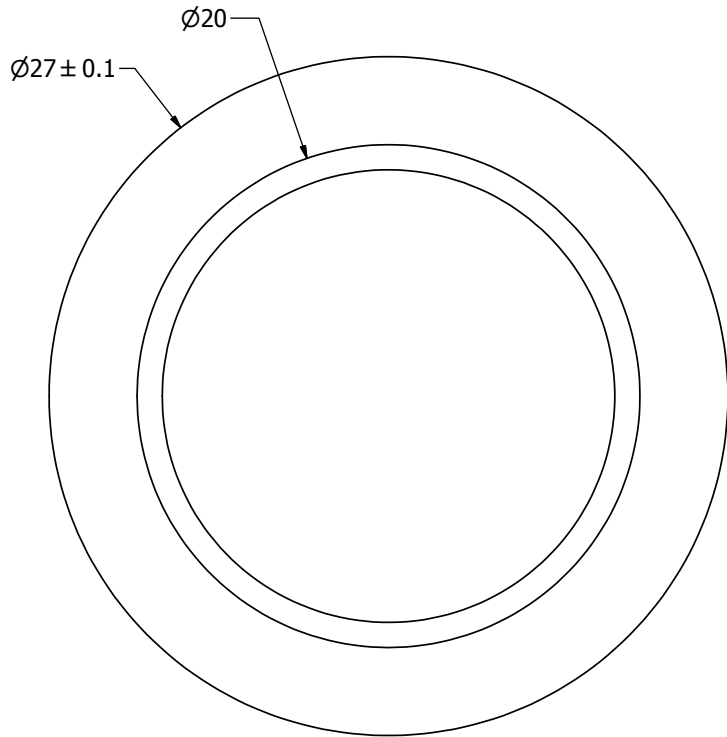

A ( 20 : 1 )

### NOTES:

1. ALL DIMENSIONS ARE IN MILLIMETERS.
2. SPECIFICATIONS SUBJECT TO CHANGE OR WITHDRAWL WITHOUT NOTICE.
3. THIS PART IS RoHS 2002/95/EC COMPLIANT.

UNLESS OTHERWISE SPECIFIED: DIMENSIONS ARE IN MILLIMETERS, TOLERANCES ARE ±0.5 AND ANGLES ARE ±3°.	SIZE	Designed by	Date	Checked by	Date	Approved by	Date	Drawn Date	
	A3	RABL	4/9/2002			S.J.	4/10/2002	8/11/2010	
AB2720B.idw	 <b>pui audio</b> a projects unlimited company		<b>AB2720B</b>			<b>Bender</b>		Edition -	Sheet 1 / 1