

SPECIFICATIONS

PARAMETERS	VALUES	UNITS
RESONANT FREQUENCY	4,600 ± 500	Hz
RESONANT IMPEDANCE (MAX)	250	Ohm
MAX INPUT VOLTAGE	30	Vp-p
CAPACITANCE @ 1kHz	16,000 ±30%	pF
PLATE MATERIAL	BRASS	-
OPERATING TEMPERATURE	-20 ~ +60	°C
STORAGE TEMPERATURE	-30 ~ +70	°C

THIS DOCUMENT CONTAINS DATA PROPRIETARY TO PROJECTS UNLIMITED, INC. ANY USE OR REPRODUCTION, IN ANY FORM, WITHOUT PRIOR WRITTEN PERMISSION OF PROJECTS UNLIMITED, INC. IS PROHIBITED.
©2003, Projects Unlimited Inc.

REVISION HISTORY

LTR	DESCRIPTION	DATE	APPROVED
-	RELEASED FROM ENGINEERING	11/6/2007	
A	REVISED TO INVENTOR 3-D DRAWING TEMPLATE	5/10/2013	B.R.

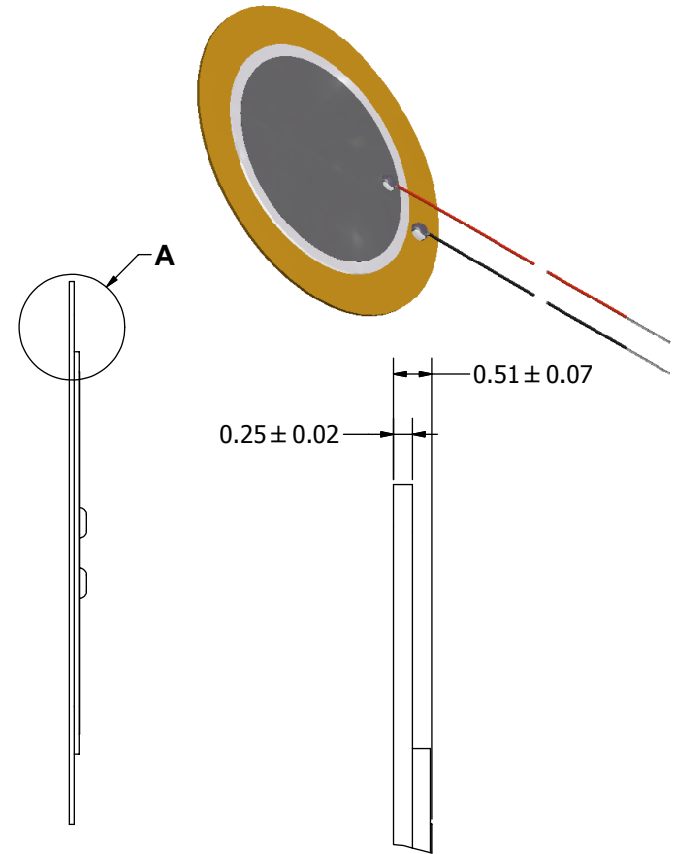
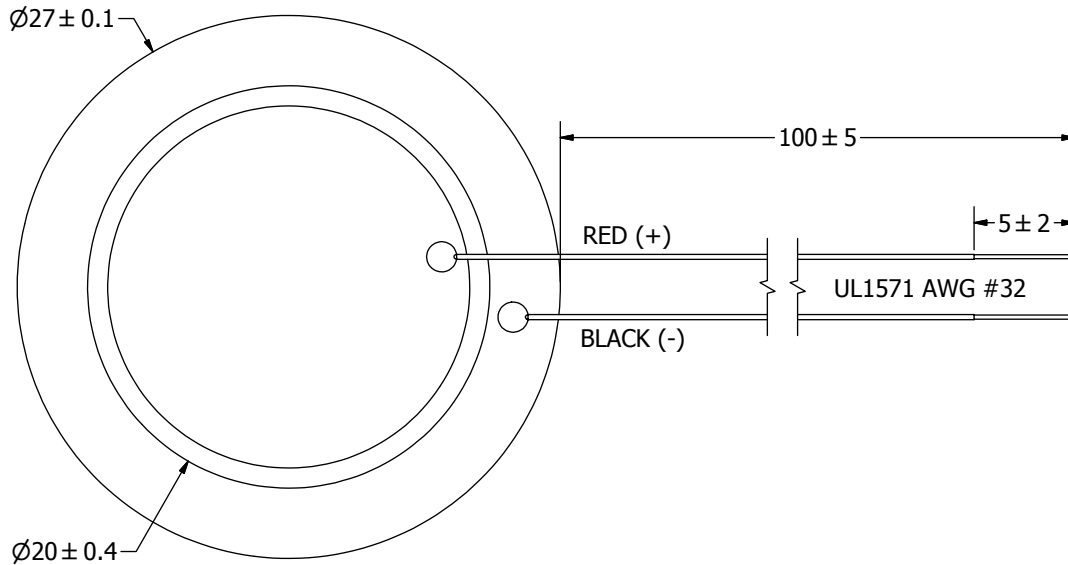

A (15 : 1)

NOTES:

1. ALL DIMENSIONS ARE IN MILLIMETERS.
2. SPECIFICATIONS SUBJECT TO CHANGE OR WITHDRAWAL WITHOUT NOTICE.
3. THIS PART IS RoHS 2011/65/EU COMPLIANT.

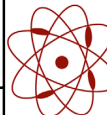
UNLESS OTHERWISE SPECIFIED: DIMENSIONS ARE IN MILLIMETERS, TOLERANCES ARE ±0.5 AND ANGLES ARE ±3°.	SIZE	Designed by	Date	Checked by	Date	Approved by	Date	Drawn Date	
	A3	J.D.	5/9/2013	C.W.	5/9/2013	B.R.	5/9/2013	5/9/2013	
AB2746B-LW100-R.idw	 pui audio a projects unlimited company		AB2746B-LW100-R			Bender		Edition -	Sheet 1 / 1