

SPECIFICATIONS

PARAMETERS	VALUES	UNITS
RATED VOLTAGE	12	Vdc
OPERATING VOLTAGE RANGE	4 ~ 32	Vdc
RATED CURRENT (MAX)	9	mA
MINIMUM SPL @ 10 CM	98	dBA
RESONANT FREQUENCY	2,800 ± 500	Hz
tone OR PULSE RATE	SLOW PULSE	1.5 pulse /sec
OPERATING TEMPERATURE	-20 ~ +60	°C
STORAGE TEMPERATURE	-30 ~ +60	°C
HOUSING MATERIAL	ABS	-
TERMINAL MATERIAL	Sn PLATED BRONZE	-
WEIGHT	16	grams

THIS DOCUMENT CONTAINS DATA PROPRIETARY TO PROJECTS UNLIMITED, INC. ANY USE OR REPRODUCTION, IN ANY FORM, WITHOUT PRIOR WRITTEN PERMISSION OF PROJECTS UNLIMITED, INC. IS PROHIBITED.
©2003, Projects Unlimited Inc.

REVISION HISTORY

LTR	DESCRIPTION	DATE	APPROVED
-	RELEASED FROM ENGINEERING	7/10/2006	
A	REVISED VOLTAGE RANGE	1/28/2008	B.R.
B	REVISED TO INVENTOR 3-D DRAWING TEMPLATE	2/25/2008	B.R.

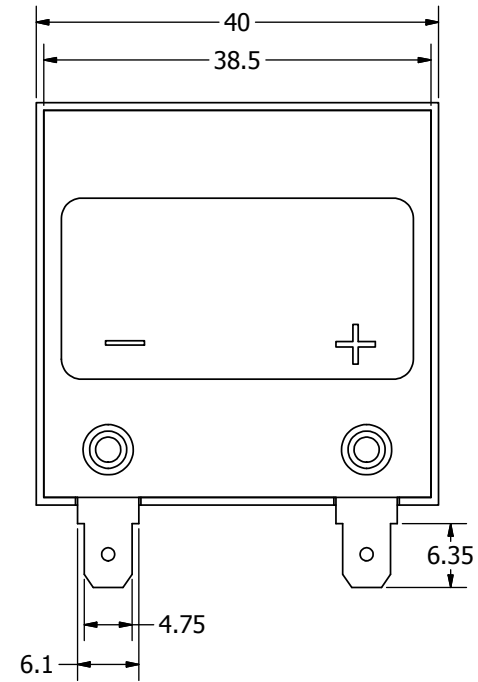
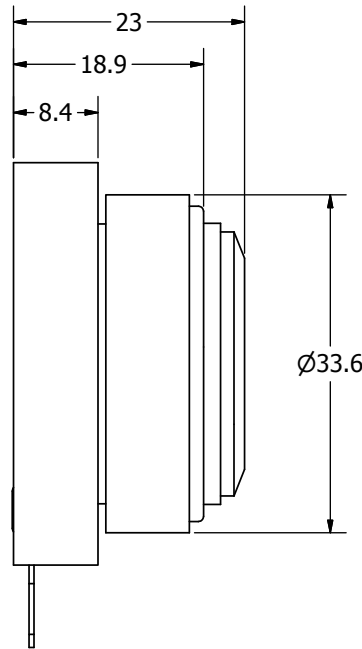
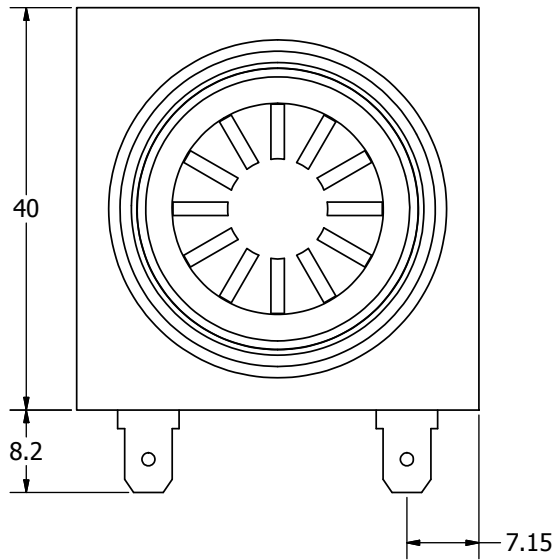
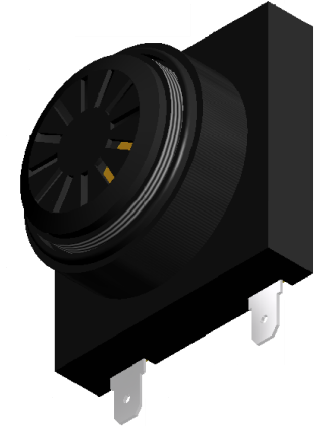

NOTES:

1. ALL DIMENSIONS ARE IN MILLIMETERS.
2. SPECIFICATIONS SUBJECT TO CHANGE OR WITHDRAWAL WITHOUT NOTICE.
3. THIS PART IS RoHS 2002/95/EC COMPLIANT.

UNLESS OTHERWISE SPECIFIED: DIMENSIONS ARE IN MILLIMETERS, TOLERANCES ARE ±0.5 AND ANGLES ARE ±3°.	SIZE A3	Designed by	Date	Checked by	Date	Approved by	Date	Drawn Date
		J.D.	7/10/2006	E.P.	7/10/2006	R.W.	7/10/2006	2/25/2008
AI-4028-P-SP32-R.idw		 pui audio a projects unlimited company		AI-4028-P-SP32-R			Indicator	
						Edition	Sheet	
						-	1 / 1	