

SPECIFICATIONS

PARAMETERS	VALUES	UNITS
RATED INPUT POWER	1	W
MAX INPUT POWER	2	W
IMPEDANCE	8 ± 15%	OHM
OUTPUT SPL @ 1W/1M (AT 0.6, 0.8, 1.0, 1.2 kHz)	80 ± 3	dB
DISTORTION (MAX.)	5%	-
RESONANT FREQUENCY	500 ± 100	Hz
FREQUENCY RANGE	500 ~ 20,000	Hz
HOUSING MATERIAL	METAL	-
CONE MATERIAL	MYLAR	-
MAGNET MATERIAL	N35	-
OPERATING TEMPERATURE	-20 ~ +55	°C
WEIGHT	6.5	grams

THIS DOCUMENT CONTAINS DATA PROPRIETARY TO PROJECTS UNLIMITED, INC. ANY USE OR REPRODUCTION, IN ANY FORM, WITHOUT PRIOR WRITTEN PERMISSION OF PROJECTS UNLIMITED, INC. IS PROHIBITED.
©2003, Projects Unlimited Inc.

REVISION HISTORY

LTR	DESCRIPTION	DATE	APPROVED
-	RELEASED FROM ENGINEERING	2/16/2006	
A	REVISED PART DIMENSION	4/3/2007	B.R.
B	REVISED TO INVENTOR 3-D DRAWING TEMPLATE	11/13/2007	B.R.

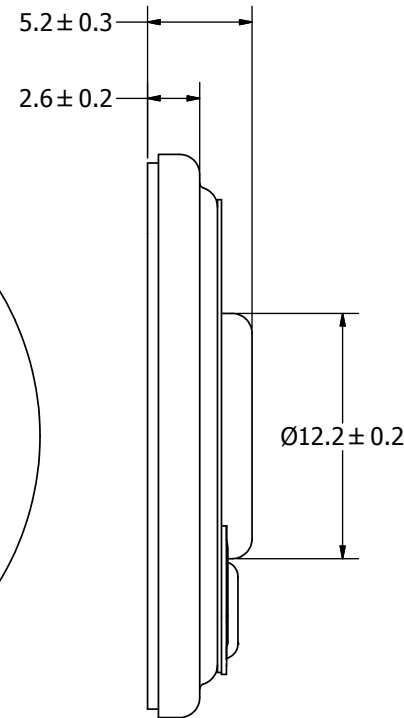
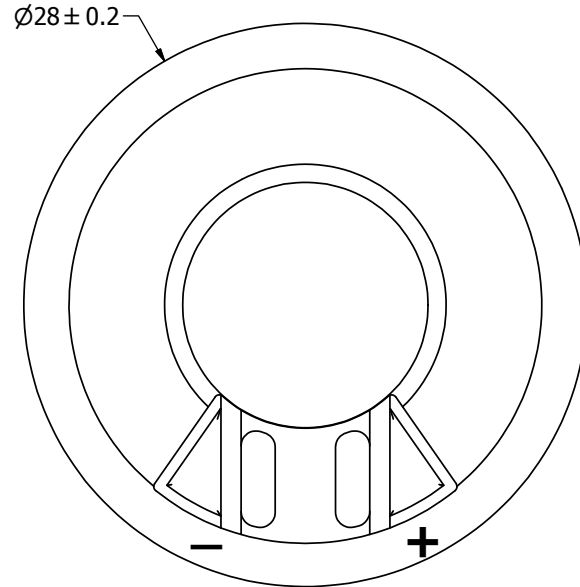

NOTES:

1. ALL DIMENSIONS ARE IN MILLIMETERS.
2. SPECIFICATIONS SUBJECT TO CHANGE OR WITHDRAWAL WITHOUT NOTICE.
3. THIS PART IS RoHS 2002/95/EC COMPLIANT.

UNLESS OTHERWISE SPECIFIED: DIMENSIONS ARE IN MILLIMETERS, TOLERANCES ARE ±0.5 AND ANGLES ARE ±3°.	SIZE	Designed by	Date	Checked by	Date	Approved by	Date	Drawn Date
	A3	J.A.F.	2/16/2006	E.P.	2/16/2006	B.R.	2/16/2006	11/13/2007
AS02808MR-R.idw		 pui audio <small>a projects unlimited company</small>			AS02808MR-R Speaker			
							Edition	Sheet
							-	1 / 1