

# SPECIFICATIONS

PARAMETERS	VALUES	UNITS
RATED INPUT POWER	2	W
MAX INPUT POWER	4	W
IMPEDANCE	4 ± 15%	OHM
OUTPUT SPL @ 1W/0.5M (AT 0.8, 1.0, 1.2, 1.5, kHz)	87 ± 3	dBA
DISTORTION (MAX.)	5%	-
RESONANT FREQUENCY	370 ± 20%	Hz
FREQUENCY RANGE	200 ~ 20,000	Hz
HOUSING MATERIAL	ABS	-
CONE MATERIAL	TREATED PAPER	-
MAGNET MATERIAL	Nd-Fe-B	-
OPERATING TEMPERATURE	-40 ~ +85	°C
WEIGHT	16.5	grams

THIS DOCUMENT CONTAINS DATA PROPRIETARY TO PROJECTS UNLIMITED, INC. ANY USE OR REPRODUCTION, IN ANY FORM, WITHOUT PRIOR WRITTEN PERMISSION OF PROJECTS UNLIMITED, INC. IS PROHIBITED.  
©2003, Projects Unlimited Inc.

# REVISION HISTORY

LTR	DESCRIPTION	DATE	APPROVED
-	RELEASED FROM ENGINEERING	12/7/2005	
A	ADDED MOUNTING HOLE DIMENSION	12/18/2007	R.W.
B	REVISED MAX. INPUT POWER	7/18/2008	B.R.
C	REVISED OPERATING TEMPERATURE	10/14/2008	C.W.
D	REVISED TO INVENTOR 3-D DRAWING TEMPLATE	11/8/2008	B.R.
E	ADDED NOTE 5	8/11/2011	B.R.

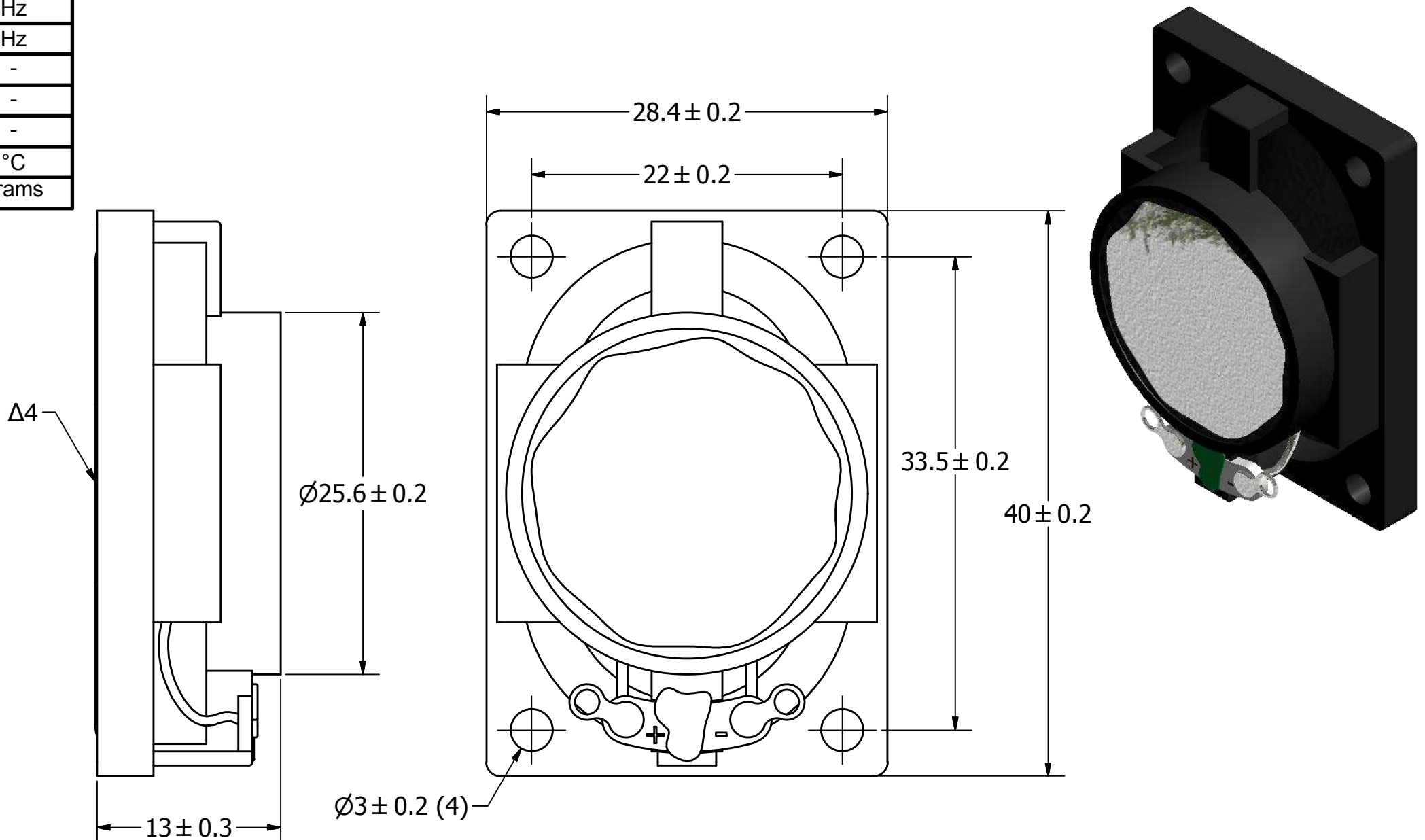

### NOTES:

1. ALL DIMENSIONS ARE IN MILLIMETERS.
2. SPECIFICATIONS SUBJECT TO CHANGE OR WITHDRAWL WITHOUT NOTICE.
3. THIS PART IS RoHS 2002/95/EC COMPLIANT.
- Δ4. CONE HAS BEEN TREATED FOR WATER RESISTANCE.
5. 5. BASE SPEAKER PUI# AS04004PO-R.

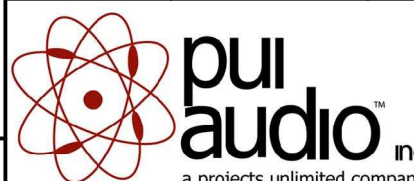
UNLESS OTHERWISE SPECIFIED: DIMENSIONS ARE IN MILLIMETERS, TOLERANCES ARE ±0.5 AND ANGLES ARE ±3°.	SIZE <b>A3</b>	Designed by	Date	Checked by	Date	Approved by	Date	Drawn Date
		J.A.F.	12/6/2005	B.R.	12/7/2005	E.P.	12/7/2005	11/8/2008
AS04004PO-WR-R.idw				<b>AS04004PO-WR-R</b> Speaker				
							Edition	Sheet
							-	1 / 1