

SPECIFICATIONS		
PARAMETERS	VALUES	UNITS
RATED INPUT POWER	2	W
MAX INPUT POWER	4	W
IMPEDANCE	8 ± 15%	OHM
OUTPUT SPL @ 1W/1M (AT 0.6, 0.8, 1.0, 1.2, 1.5 kHz)	86 ± 3	dB
DISTORTION (MAX.)	7%	-
RESONANT FREQUENCY	300 ± 20%	Hz
FREQUENCY RANGE	300 ~ 20,000	Hz
HOUSING MATERIAL	METAL	-
CONE MATERIAL	TREATED PAPER	-
MAGNET MATERIAL	FERRITE	-
OPERATING TEMPERATURE	-25 ~ +55	°C
WEIGHT	143	grams

THIS DOCUMENT CONTAINS DATA PROPRIETARY TO PROJECTS UNLIMITED, INC. ANY USE OR REPRODUCTION, IN ANY FORM, WITHOUT PRIOR WRITTEN PERMISSION OF PROJECTS UNLIMITED, INC. IS PROHIBITED.
©2003, Projects Unlimited Inc.

REVISION HISTORY			
LTR	DESCRIPTION	DATE	APPROVED
-	RELEASED FROM ENGINEERING	9/25/2006	
A	REVISED TO INVENTOR 3-D DRAWING TEMPLATE	1/26/2009	B.R.

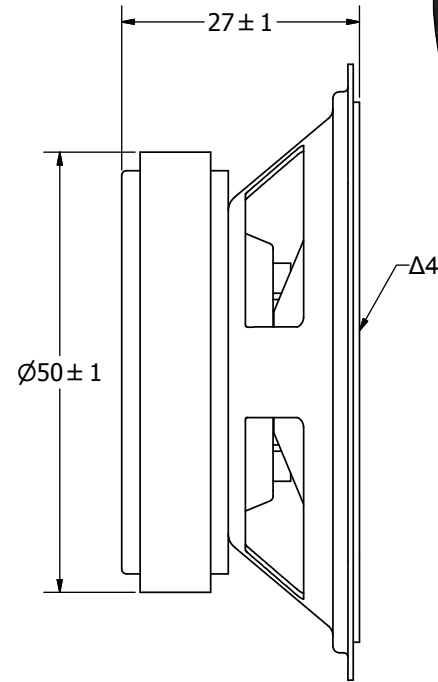
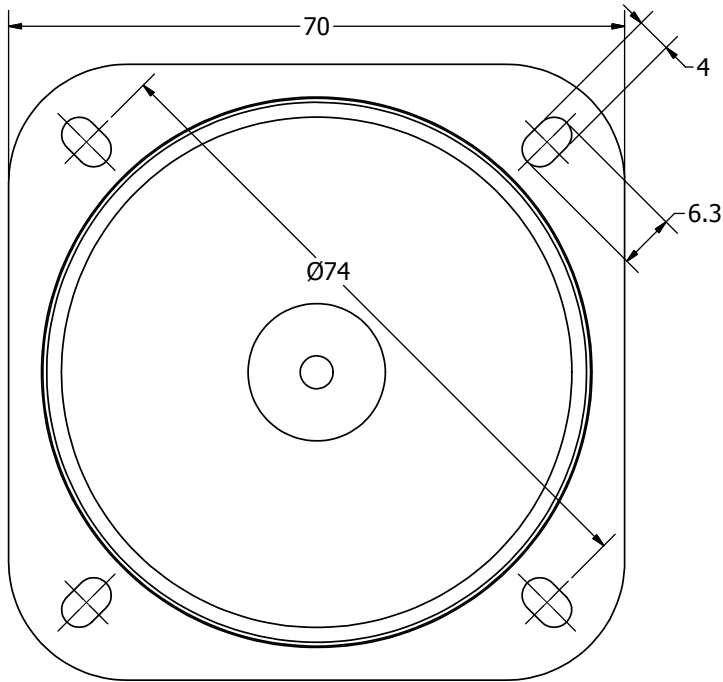

NOTES:

1. ALL DIMENSIONS ARE IN MILLIMETERS.
2. SPECIFICATIONS SUBJECT TO CHANGE OR WITHDRAWL WITHOUT NOTICE.
3. THIS PART IS RoHS 2002/95/EC COMPLIANT.
- Δ4. CONE HAS BEEN TREATED FOR WATER RESISTANCE.

UNLESS OTHERWISE SPECIFIED: DIMENSIONS ARE IN MILLIMETERS, TOLERANCES ARE ±0.5 AND ANGLES ARE ±3°.	SIZE	Designed by	Date	Checked by	Date	Approved by	Date	Drawn Date
	A3	J.D.	9/25/2006	B.R.	9/25/2006	R.W.	9/25/2006	1/26/2009
AS07008PS-WR-R.idw			AS07008PS-WR-R			Speaker		
						Edition		Sheet
						-		1 / 1