

# SPECIFICATIONS

PARAMETERS	VALUES	UNITS
RATED VOLTAGE	1.5	Vp-p
OPERATING VOLTAGE RANGE	1 ~ 3	Vp-p
RATED CURRENT (MAX)	10	mA
COIL RESISTANCE	42 ± 6	OHM
MINIMUM SPL @ 10 CM	82	dBA
RESONANT FREQUENCY	2,048 ± 500	Hz
OPERATING TEMPERATURE	-20 ~ +70	°C
STORAGE TEMPERATURE	-30 ~ +80	°C
HOUSING MATERIAL	NORYL	-
TERMINAL MATERIAL	Sn PLATED RED COPPER	-
WEIGHT	2	grams

THIS DOCUMENT CONTAINS DATA PROPRIETARY TO PROJECTS UNLIMITED, INC. ANY USE OR REPRODUCTION, IN ANY FORM, WITHOUT PRIOR WRITTEN PERMISSION OF PROJECTS UNLIMITED, INC. IS PROHIBITED.  
©2003, Projects Unlimited Inc.

# REVISION HISTORY

LTR	DESCRIPTION	DATE	APPROVED
-	RELEASED FROM ENGINEERING	9/2/2004	
A	REMOVED LEAD FREE ADDED RoHS NOTE	8/10/2005	
B	REVISED MINIMUM SPL	11/29/2007	R.W.
C	REVISED TO INVENTOR 3-D DRAWING TEMPLATE	4/7/2008	B.R.

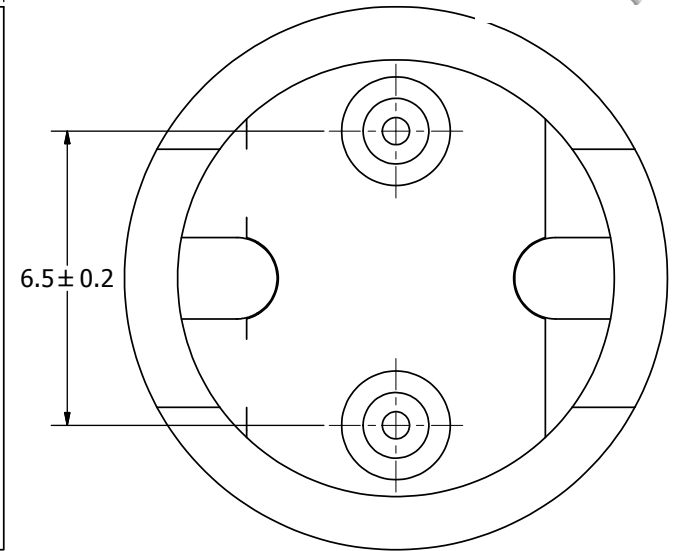
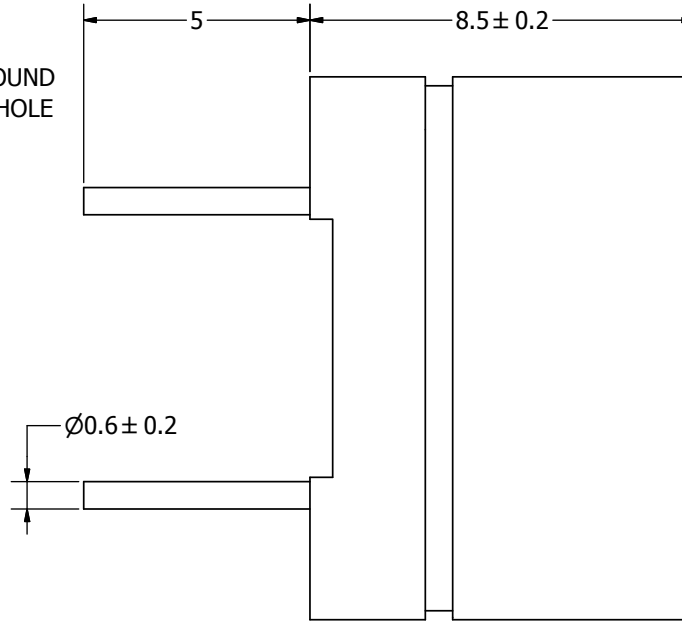
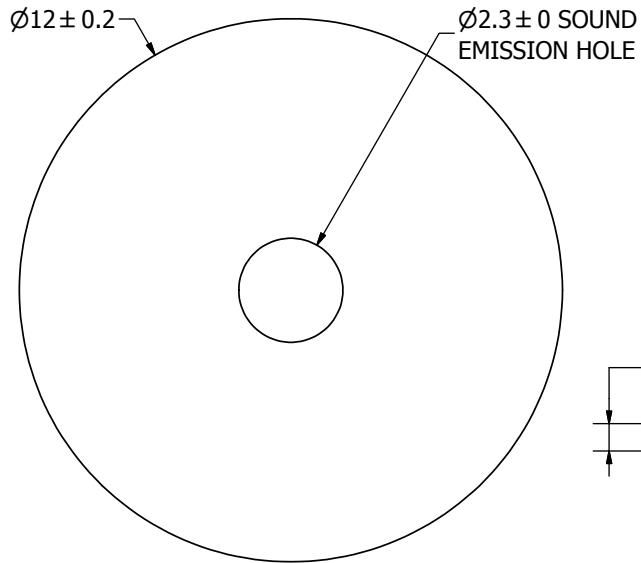
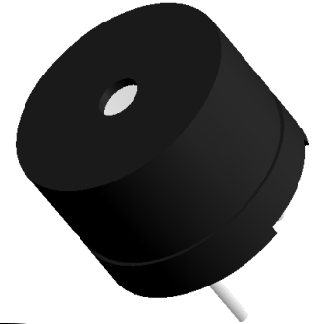

### NOTES:

1. ALL DIMENSIONS ARE IN MILLIMETERS.
2. SPECIFICATIONS SUBJECT TO CHANGE OR WITHDRAWL WITHOUT NOTICE.
3. THIS PART IS RoHS 2002/95/EC COMPLIANT.

UNLESS OTHERWISE SPECIFIED: DIMENSIONS ARE IN MILLIMETERS, TOLERANCES ARE ±0.5 AND ANGLES ARE ±3°.	SIZE <b>A3</b>	Designed by	Date	Checked by	Date	Approved by	Date	Drawn Date
		R.A.C.	9/2/2004			R.W.	9/2/2004	4/7/2008
AT-1220-TT-R.idw						<b>AT-1220-TT-R</b> Transducer (Electro-Mech)		
						Edition	Sheet	
						-	1 / 1	