

SPECIFICATIONS

PARAMETERS	VALUES	UNITS
RATED VOLTAGE	10	Vp-p
OPERATING VOLTAGE RANGE	1 ~ 30	Vp-p
RATED CURRENT (MAX)	3.5	mA
CAPACITANCE	13,000 ± 30%	pF
MINIMUM SPL @ 10 CM	88	dB
RESONANT FREQUENCY	3,000 ± 500	Hz
OPERATING TEMPERATURE	-20 ~ +60	°C
STORAGE TEMPERATURE	-30 ~ +70	°C
HOUSING MATERIAL	ABS	-
TERMINAL MATERIAL	Sn PLATED PHOSPHOR BRONZE	-
WEIGHT	2	grams

THIS DOCUMENT CONTAINS DATA PROPRIETARY TO PROJECTS UNLIMITED, INC. ANY USE OR REPRODUCTION, IN ANY FORM, WITHOUT PRIOR WRITTEN PERMISSION OF PROJECTS UNLIMITED, INC. IS PROHIBITED.
©2003, Projects Unlimited Inc.

REVISION HISTORY

LTR	DESCRIPTION	DATE	APPROVED
-	RELEASED FROM ENGINEERING	5/9/2006	
A	REVISED TO INVENTOR 3-D DRAWING TEMPLATE	8/6/2008	B.R.

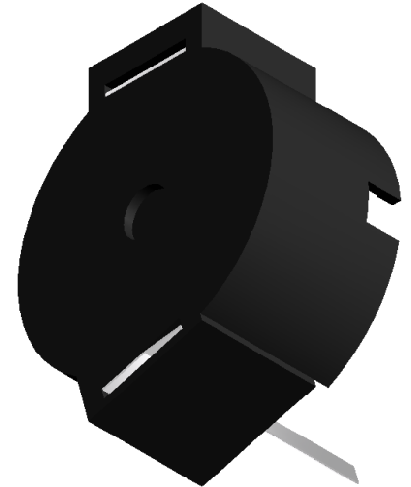
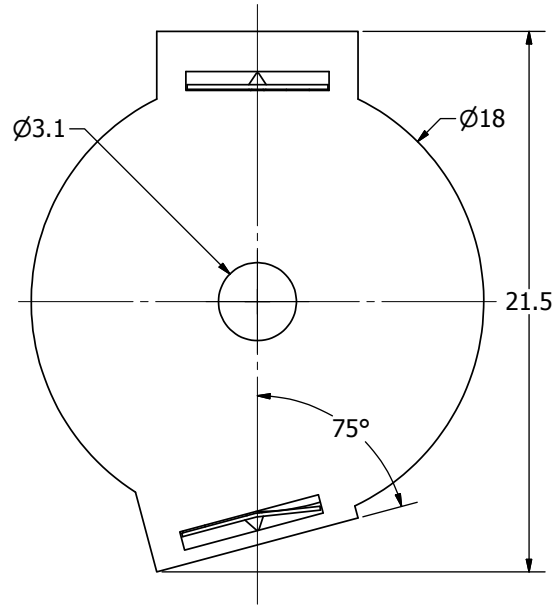
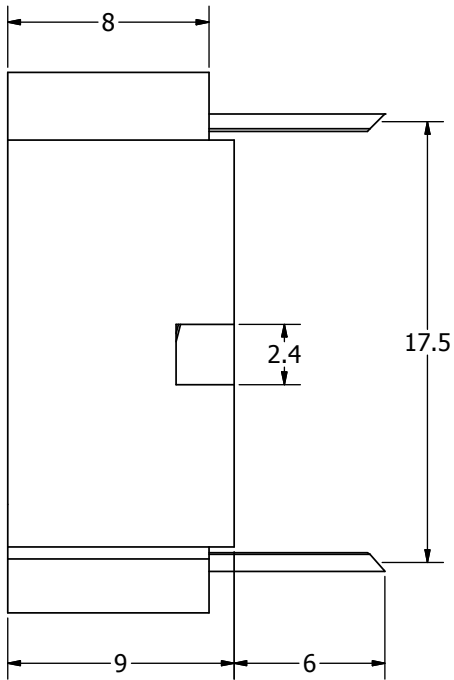

NOTES:

1. ALL DIMENSIONS ARE IN MILLIMETERS.
2. SPECIFICATIONS SUBJECT TO CHANGE OR WITHDRAWAL WITHOUT NOTICE.
3. THIS PART IS RoHS 2002/95/EC COMPLIANT.

UNLESS OTHERWISE SPECIFIED: DIMENSIONS ARE IN MILLIMETERS, TOLERANCES ARE ±0.5 AND ANGLES ARE ±3°.	SIZE	Designed by	Date	Checked by	Date	Approved by	Date	Drawn Date	
	A3	J.D.	5/9/2006	B.R.	5/9/2006	B.R.	5/9/2006	8/5/2008	
AT-1830-TT-R.idw					<h2>AT-1830-TT-R</h2>				
		Transducer (Piezo)			Edition	Sheet			
					-	1 / 1			