

# SPECIFICATIONS

PARAMETERS	VALUES	UNIT
RATED VOLTAGE	5	Vp-p
OPERATING VOLTAGE RANGE	1 ~ 30	Vp-p
RATED CURRENT (MAX)	5	mA
CAPACITANCE	55,000 ± 30%	pF
MINIMUM SPL @ 10 CM	86	dBA
RESONANT FREQUENCY	1,100 ± 500	Hz
OPERATING TEMPERATURE	-20 ~ +70	°C
STORAGE TEMPERATURE	-30 ~ +80	°C
HOUSING MATERIAL	ABS	-
TERMINAL MATERIAL	LEAD WIRE	-
WEIGHT	6	grams

THIS DOCUMENT CONTAINS DATA PROPRIETARY TO PROJECTS UNLIMITED, INC. ANY USE OR REPRODUCTION, IN ANY FORM, WITHOUT PRIOR WRITTEN PERMISSION OF PROJECTS UNLIMITED, INC. IS PROHIBITED.  
©2003, Projects Unlimited Inc.

## REVISION HISTORY

LTR	DESCRIPTION	DATE	APPROVED
-	RELEASED FROM ENGINEERING	12/18/2006	
A	ADDED RoHS STATEMENTS & WIRE TYPE	1/03/2007	D.F.
B	REVISED TO INVENTOR 3-D DRAWING TEMPLATE	8/28/2008	B.R.

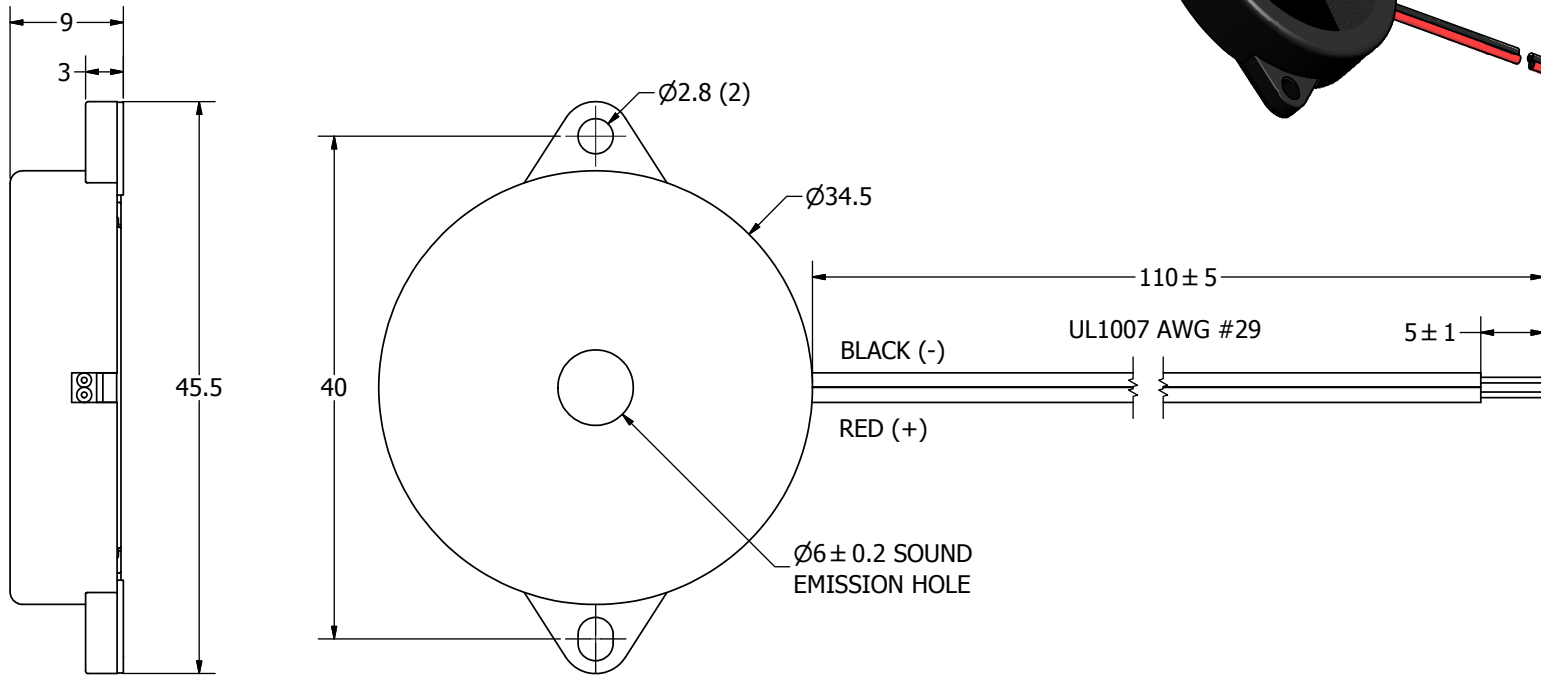
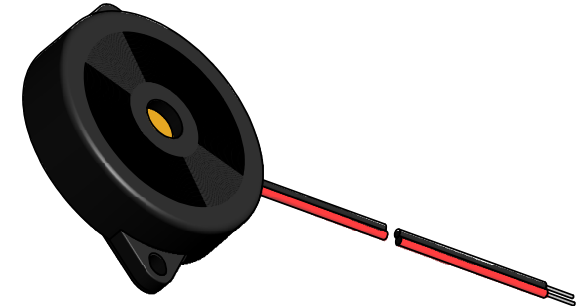

### NOTES:

1. ALL DIMENSIONS ARE IN MILLIMETERS.
2. SPECIFICATIONS SUBJECT TO CHANGE OR WITHDRAWAL WITHOUT NOTICE.
3. THIS PART IS RoHS 2002/95/EC COMPLIANT.

UNLESS OTHERWISE SPECIFIED: DIMENSIONS ARE IN MILLIMETERS, TOLERANCES ARE ±0.5 AND ANGLES ARE ±3°.	SIZE <b>A3</b>	Designed by	Date	Checked by	Date	Approved by	Date	Drawn Date
		J.D.	11/30/2006	D.F.	12/18/2006	R.W.	12/18/2006	8/28/2008
AT-3311-TF-LW110-R.idw		 <b>pui audio</b> A Division of Projects Unlimited		<b>AT-3311-TF-LW110-R</b> Transducer (Piezo)			Edition	Sheet
						-	1 / 1	