

## SPECIFICATIONS

| PARAMETERS                    | VALUES            | UNITS |
|-------------------------------|-------------------|-------|
| RATED VOLTAGE                 | 24                | Vdc   |
| OPERATING VOLTAGE RANGE       | 9 ~ 28            | Vdc   |
| TONE OUTPUT                   | SEE 32 TONE CHART | -     |
| CURRENT CONSUMPTION (NOMINAL) | SEE 32 TONE CHART | mA    |
| INGRESS PROTECTION            | IP42              | -     |
| CASE MATERIAL/COLOR           | ABS/WHITE         | -     |
| TERMINAL                      | SCREW             | -     |
| OPERATING TEMPERATURE         | -25 ~ +55         | °C    |
| WEIGHT                        | 580               | grams |

THIS DOCUMENT CONTAINS DATA PROPRIETARY TO PROJECTS UNLIMITED, INC. ANY USE OR REPRODUCTION, IN ANY FORM, WITHOUT PRIOR WRITTEN PERMISSION OF PROJECTS UNLIMITED, INC. IS PROHIBITED.  
©2003, Projects Unlimited Inc.

## REVISION HISTORY

| LTR | DESCRIPTION                              | DATE       | APPROVED |
|-----|--|------------|----------|
| -   | RELEASED FROM ENGINEERING                | 12/20/2005 |          |
| A   | ADDED RoHS NOTE                          | 5/22/2007  | R.W.     |
| B   | REVISED TO INVENTOR 3-D DRAWING TEMPLATE | 6/22/2010  | B.R.     |

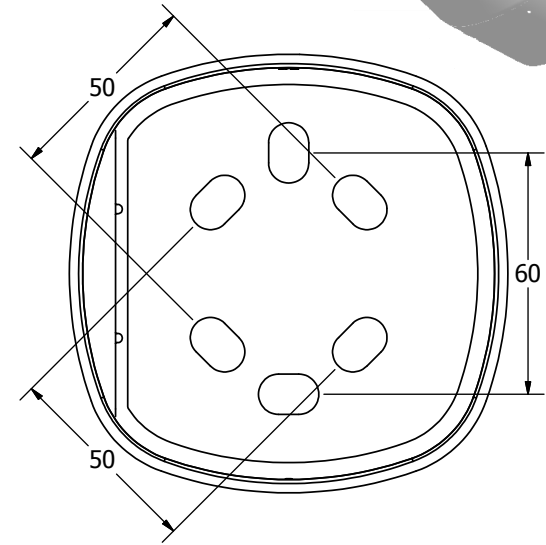
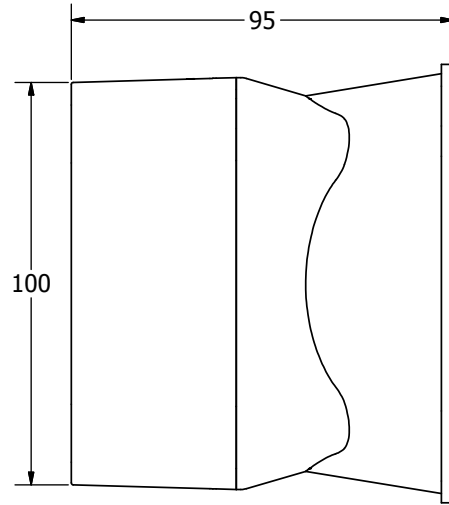
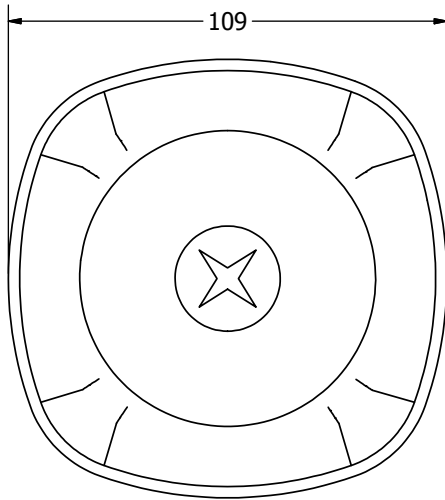
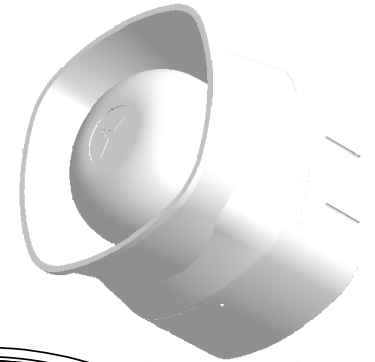

### NOTES:

1. ALL DIMENSIONS ARE IN MILLIMETERS.
2. SPECIFICATIONS SUBJECT TO CHANGE OR WITHDRAWL WITHOUT NOTICE.
3. THIS PART IS RoHS 2002/95/EC COMPLIANT.

|  |      |             |            |            |            |                 |            |            |
|--|------|-------------|------------|------------|------------|-----------------|------------|------------|
| UNLESS OTHERWISE SPECIFIED:<br>DIMENSIONS ARE IN MILLIMETERS,<br>TOLERANCES ARE ±0.5 AND ANGLES ARE ±3°. | SIZE | Designed by | Date       | Checked by | Date       | Approved by     | Date       | Drawn Date |
|  | A3   | J.A.F.      | 12/20/2005 | E.P.       | 12/20/2005 | B.R.            | 12/20/2005 | 6/22/2010  |
| AW-30SBW.idw   |      |             |            |            |            | <b>AW-30SBW</b> |            |            |
|  |      |             |            |            |            | <b>Siren</b>    |            | Edition    |
|  |      |             |            | -          |            | 1 / 1           |            |            |