

SPECIFICATIONS

PARAMETERS	VALUES	UNITS
RATED VOLTAGE (SQUARE WAVE)	3	Vp-p
OPERATING VOLTAGE RANGE	2 ~ 4	Vp-p
RATED CURRENT (MAX)	100	mA
COIL RESISTANCE	12 ± 2	OHM
MINIMUM SPL @ 10 CM	78	dB
RESONANT FREQUENCY	4,000 ± 500	Hz
OPERATING TEMPERATURE	-30 ~ +70	°C
STORAGE TEMPERATURE	-40 ~ +85	°C
HOUSING MATERIAL	LCP	-
TERMINAL MATERIAL	Au PLATED PHOSPHOR BRONZE	-
WEIGHT	0.2	grams

THIS DOCUMENT CONTAINS DATA PROPRIETARY TO PROJECTS UNLIMITED, INC. ANY USE OR REPRODUCTION, IN ANY FORM, WITHOUT PRIOR WRITTEN PERMISSION OF PROJECTS UNLIMITED, INC. IS PROHIBITED.
©2003, Projects Unlimited Inc.

REVISION HISTORY

LTR	DESCRIPTION	DATE	APPROVED
-	RELEASED FROM ENGINEERING	3/31/2006	
A	REVISED TO INVENTOR 3-D DRAWING TEMPLATE	12/13/2007	B.R.
B	REVISED TOLERANCES ON DIMENSIONS	8/27/2010	B.R.
C	REVISED LOWER HOUSING AND TERMINAL MATERIAL	2/24/2011	B.R.

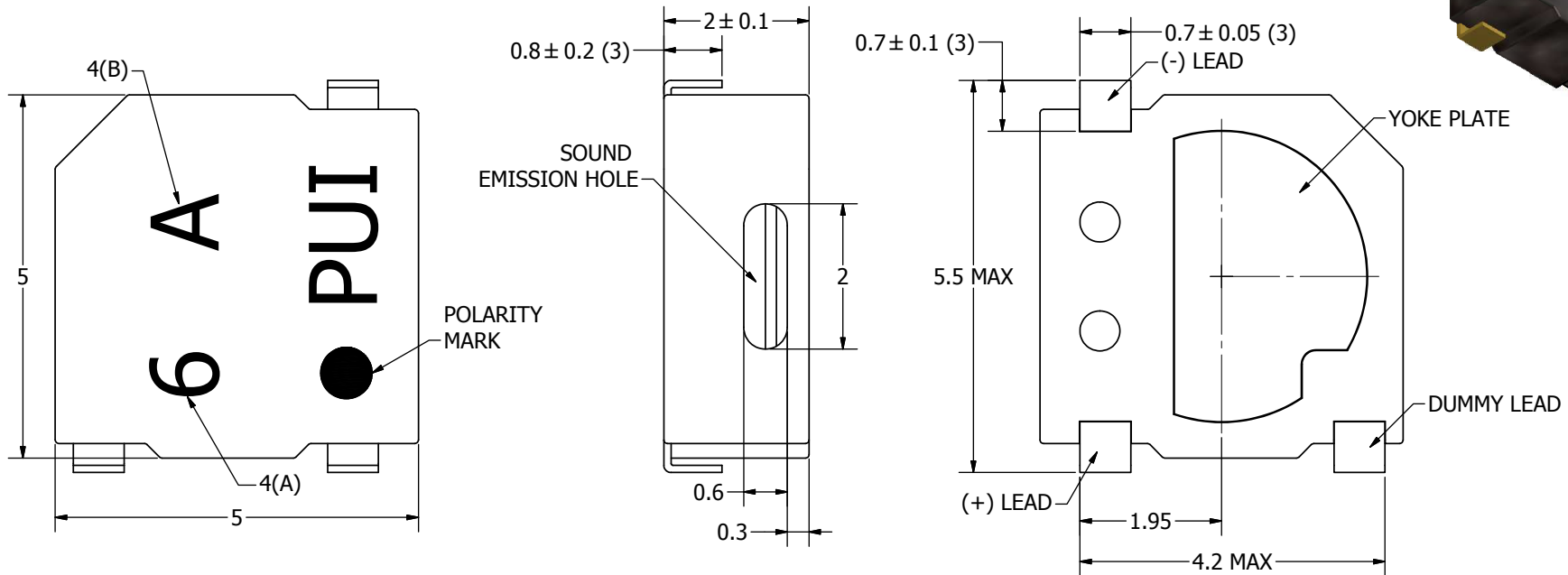

NOTES:

1. ALL DIMENSIONS ARE IN MILLIMETERS.
2. SPECIFICATIONS SUBJECT TO CHANGE OR WITHDRAWAL WITHOUT NOTICE.
3. THIS PART IS RoHS 2002/95/EC COMPLIANT.
4. DATE CODE: A. FIRST DIGIT REPRESENTS THE No. OF THE YEAR.
B. LAST DIGIT REPRESENTS THE MONTH. (A=JAN.~L=DEC.)

UNLESS OTHERWISE SPECIFIED: DIMENSIONS ARE IN MILLIMETERS, TOLERANCES ARE ±0.5 AND ANGLES ARE ±3°.	SIZE A3	Designed by	Date	Checked by	Date	Approved by	Date	Drawn Date	
		B.R.	3/31/2006	B.R.	3/31/2006	E.P.	3/31/2006	12/13/2007	
SMT-0540-S-R.idw				SMT-0540-S-R					
Transducer (Electro-Mech)							Edition	Sheet	
							-	1 / 1	