

SPECIFICATIONS

PARAMETERS	VALUES	UNIT
RATED VOLTAGE	3	Vp-p
OPERATING VOLTAGE RANGE	2 ~ 4	Vp-p
RATED CURRENT (MAX)	100	mA
COIL RESISTANCE	12 ± 2	OHM
MINIMUM SPL @ 10 CM	78	dBA
RESONANT FREQUENCY	4,000 ± 500	Hz
OPERATING TEMPERATURE	-30 ~ +70	°C
STORAGE TEMPERATURE	-40 ~ +85	°C
HOUSING MATERIAL	LCP	-
TERMINAL MATERIAL	Au PLATED PHOSPHOR BRONZE	-
WEIGHT	0.25	grams

THIS DOCUMENT CONTAINS DATA PROPRIETARY TO PROJECTS UNLIMITED, INC. ANY USE OR REPRODUCTION, IN ANY FORM, WITHOUT PRIOR WRITTEN PERMISSION OF PROJECTS UNLIMITED, INC. IS PROHIBITED.
©2003, Projects Unlimited Inc.

REVISION HISTORY

LTR	DESCRIPTION	DATE	APPROVED
-	RELEASED FROM ENGINEERING	6/18/2008	
A	REVISED TO INVENTOR 3-D DRAWING TEMPLATE	6/4/2010	B.R.

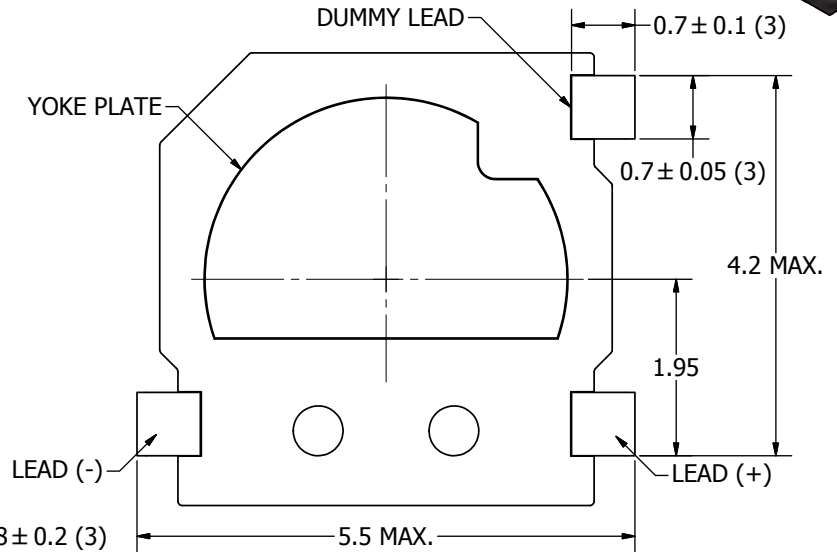
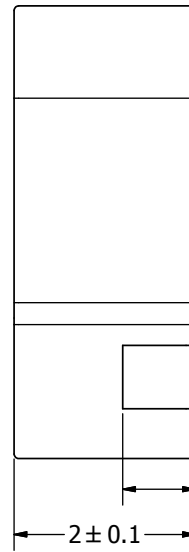
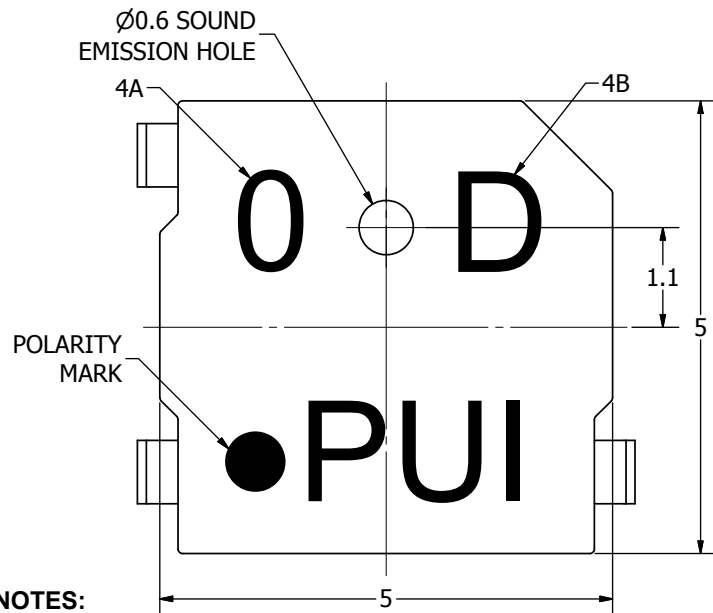
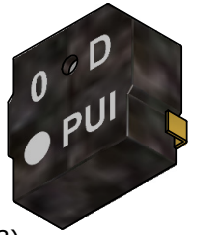

NOTES:

- ALL DIMENSIONS ARE IN MILLIMETERS.
- SPECIFICATIONS SUBJECT TO CHANGE OR WITHDRAWL WITHOUT NOTICE.
- THIS PART IS RoHS 2002/95/EC COMPLIANT.
- DATE CODE:
A. FIRST DIGIT REPRESENTS THE NO. OF THE YEAR.
B. LAST DIGIT REPRESENTS THE MONTH. (A-JAN~L-DEC.)

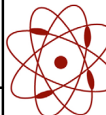
UNLESS OTHERWISE SPECIFIED:	SIZE	Designed by	Date	Checked by	Date	Approved by	Date	Drawn Date
DIMENSIONS ARE IN MILLIMETERS, TOLERANCES ARE ±0.5 AND ANGLES ARE ±3°.	A3	J.D.	6/18/2008	C.W.	6/18/2008	B.R.	6/18/2008	6/4/2010
SMT-0540-T-7-R.idw		 pui audio a projects unlimited company				SMT-0540-T-7-R		
Transducer (Electro-Mech)							Edition	Sheet
							-	1 / 1