

THIS DOCUMENT CONTAINS DATA PROPRIETARY TO PROJECTS UNLIMITED, INC. ANY USE OR REPRODUCTION, IN ANY FORM, WITHOUT PRIOR WRITTEN PERMISSION OF PROJECTS UNLIMITED, INC. IS PROHIBITED.
©2005, Projects Unlimited Inc.

SPECIFICATIONS

PARAMETERS	VALUES	UNITS
RATED VOLTAGE (SQUARE WAVE)	3.6	Vp-p
OPERATING VOLTAGE RANGE	2.5 ~ 4.5	Vp-p
RATED CURRENT (MAX)	90	mA
COIL RESISTANCE	15±3	OHM
MINIMUM SPL @ 10 CM	85	dB
RESONANT FREQUENCY	2,700±500	Hz
OPERATING TEMPERATURE	-40 ~ +70	°C
STORAGE TEMPERATURE	-40 ~ +85	°C
HOUSING MATERIAL	LCP	-
TERMINAL MATERIAL	Sn Plated Phosphor Bronze	-
WEIGHT	.4	grams

REVISIONS			
LTR	DESCRIPTION	DATE	APPROVED
-	RELEASED FROM ENGINEERING	4/1/05	
A	ADDED RoHS NOTE	8/11/05	
B	REVISED OPERATING TEMPERATURE	2/28/07	D.F.

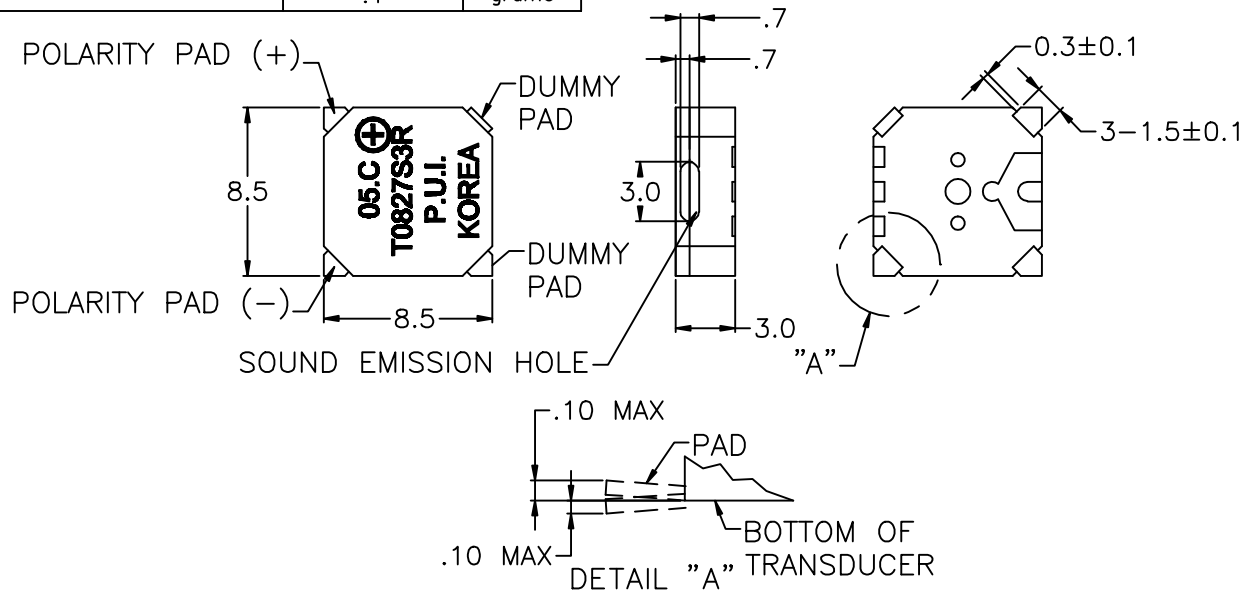

NOTES:

1. ALL DIMENSIONS ARE IN MILLIMETERS.
2. SPECIFICATION SUBJECT TO CHANGE OR WITHDRAWAL WITHOUT NOTICE.
3. THIS PART IS RoHS 2002/95/EC COMPLIANT.

UNLESS OTHERWISE SPECIFIED: DIMENSIONS ARE IN MILLIMETERS, TOLERANCES ARE ±0.5 AND ANGLES ARE ±3°.



Dayton, Ohio

TRANSDUCER (ELECTRO-MECH)

APPROVALS	DATE
DRAWN G.V.	3/31/05
CHECKED E.P.	4/1/05
APPROVED R.W.	4/1/05

SIZE A

DRAWING NO. SMT-0827-S-3-R

FILE NAME SMT-0827-S-3-R.DWG

DO NOT SCALE DRAWING

SCALE: N.T.S.

SHEET 1 OF 1