

SPECIFICATIONS

PARAMETERS	VALUES	UNIT
RATED VOLTAGE	3.6	Vp-p
OPERATING VOLTAGE RANGE	2.5 ~ 4.5	Vp-p
RATED CURRENT (MAX)	90	mA
COIL RESISTANCE	16 ± 2.4	OHM
MINIMUM SPL @ 10 CM	90	dB
RESONANT FREQUENCY	2,670 ± 500	Hz
OPERATING TEMPERATURE	-30 ~ +70	°C
STORAGE TEMPERATURE	-40 ~ +85	°C
HOUSING MATERIAL	LCP	-
TERMINAL MATERIAL	PBS	-
WEIGHT	0.4	grams

THIS DOCUMENT CONTAINS DATA PROPRIETARY TO PROJECTS UNLIMITED, INC. ANY USE OR REPRODUCTION, IN ANY FORM, WITHOUT PRIOR WRITTEN PERMISSION OF PROJECTS UNLIMITED, INC. IS PROHIBITED.
©2003, Projects Unlimited Inc.

REVISION HISTORY

LTR	DESCRIPTION	DATE	APPROVED
-	RELEASED FROM ENGINEERING	10/18/2006	
A	REVISED OPERATING VOLTAGE RANGE	10/24/2006	
B	REVISED TO INVENTOR 3-D DRAWING TEMPLATE	5/4/2010	B.R.

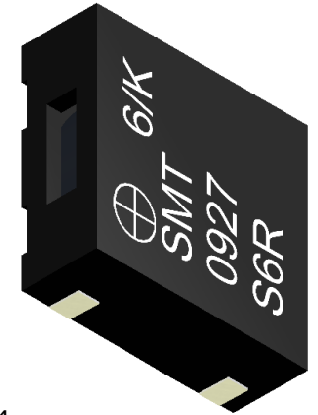
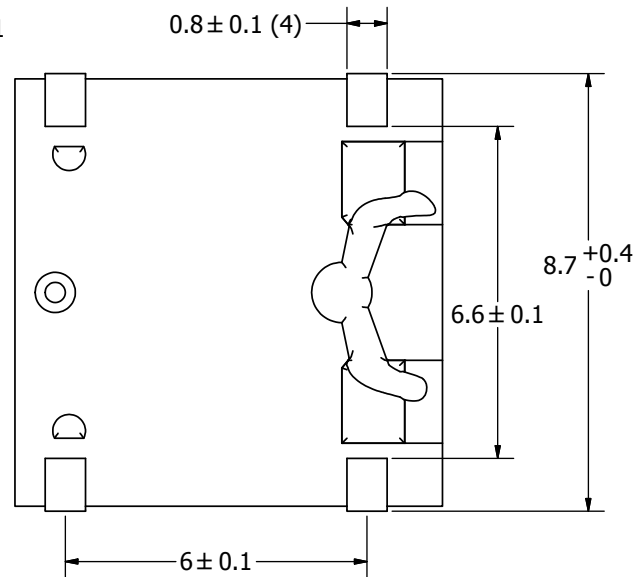
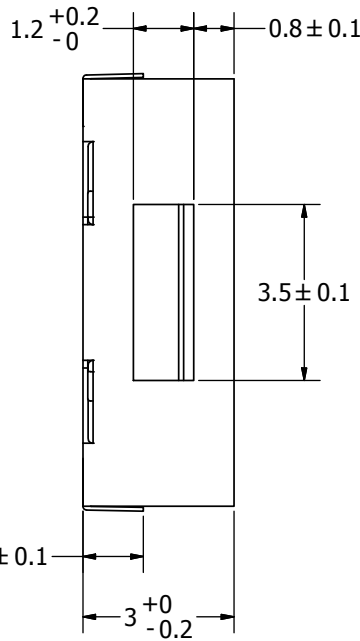
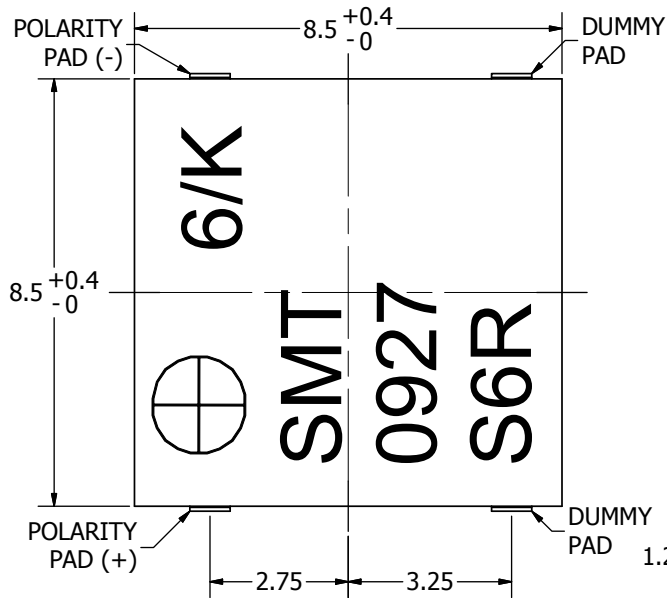

NOTES:

1. ALL DIMENSIONS ARE IN MILLIMETERS.
2. SPECIFICATIONS SUBJECT TO CHANGE OR WITHDRAWAL WITHOUT NOTICE.
3. THIS PART IS RoHS 2002/95/EC COMPLIANT.

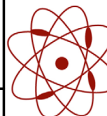
UNLESS OTHERWISE SPECIFIED: DIMENSIONS ARE IN MILLIMETERS, TOLERANCES ARE ±0.5 AND ANGLES ARE ±3°.	SIZE A3	Designed by	Date	Checked by	Date	Approved by	Date	Drawn Date	
		J.D.	10/18/2006	R.W.	10/18/2006	R.W.	10/18/2006	5/5/2010	
SMT-0927-S-6-R.idw		 pui audio a projects unlimited company				SMT-0927-S-6-R Transducer (Electro-Mech)		Edition -	Sheet 1 / 1