

SPECIFICATIONS

PARAMETERS	VALUES	UNITS
RATED VOLTAGE	5	Vp-p
OPERATING VOLTAGE RANGE	4 ~ 6	Vp-p
RATED CURRENT (MAX)	70	mA
COIL RESISTANCE	32 ± 5	OHM
MINIMUM SPL @ 10 CM	93	dBA
RESONANT FREQUENCY	2,830 ± 500	Hz
OPERATING TEMPERATURE	-20 ~ +70	°C
STORAGE TEMPERATURE	-30 ~ +85	°C
HOUSING MATERIAL	PA46	-
TERMINAL MATERIAL	Au PLATED Cu WRAPPED FR4	-
WEIGHT	1	grams

THIS DOCUMENT CONTAINS DATA PROPRIETARY TO PROJECTS UNLIMITED, INC. ANY USE OR REPRODUCTION, IN ANY FORM, WITHOUT PRIOR WRITTEN PERMISSION OF PROJECTS UNLIMITED, INC. IS PROHIBITED.
©2003, Projects Unlimited Inc.

REVISION HISTORY

LTR	DESCRIPTION	DATE	APPROVED
-	RELEASED FROM ENGINEERING	10/18/2006	
A	REVISED TO INVENTOR 3-D DRAWING TEMPLATE	6/4/2010	B.R.

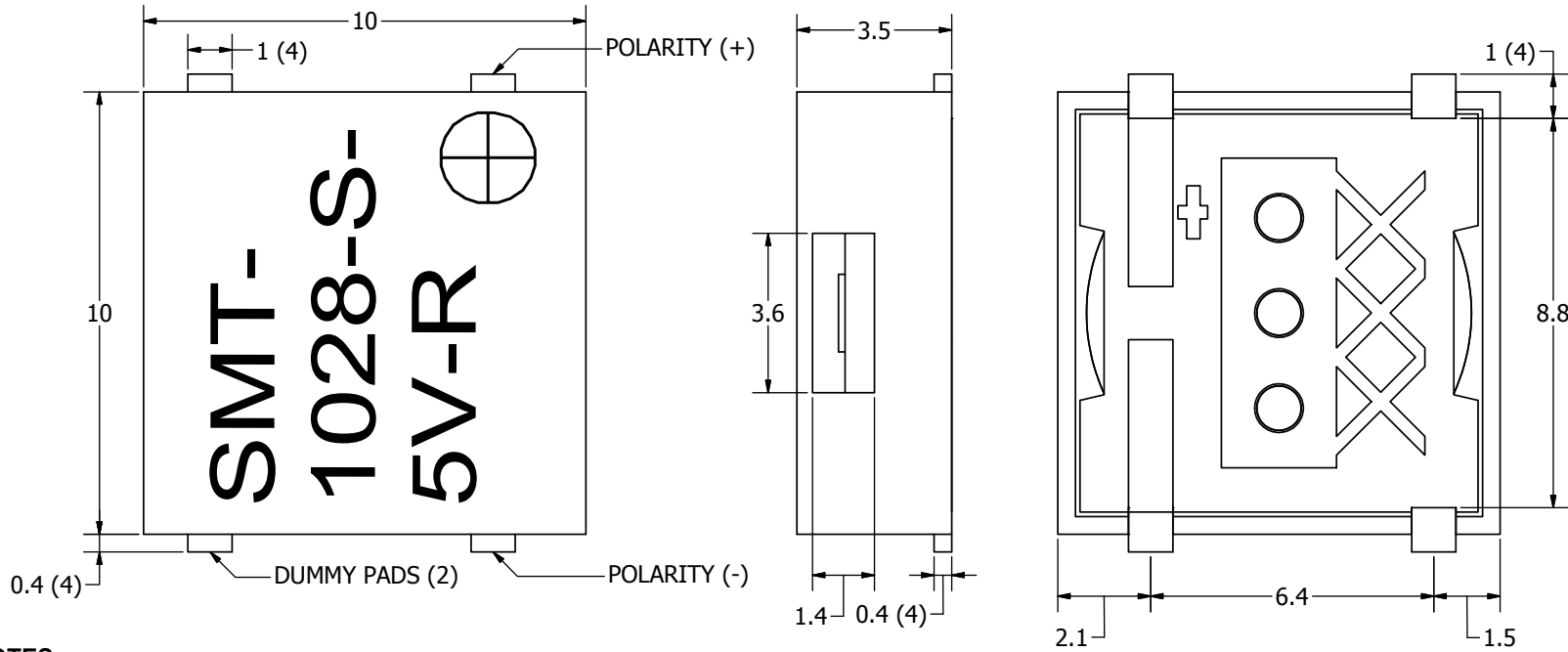
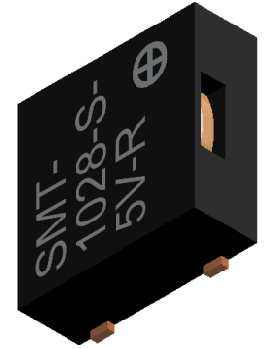

NOTES:

1. ALL DIMENSIONS ARE IN MILLIMETERS.
2. SPECIFICATIONS SUBJECT TO CHANGE OR WITHDRAWAL WITHOUT NOTICE.
3. THIS PART IS RoHS 2002/95/EC COMPLIANT.

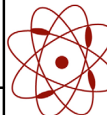
UNLESS OTHERWISE SPECIFIED: DIMENSIONS ARE IN MILLIMETERS, TOLERANCES ARE ±0.5 AND ANGLES ARE ±3°.	SIZE	Designed by	Date	Checked by	Date	Approved by	Date	Drawn Date
	A3	J.D.	10/18/2006	B.R.	10/18/2006	R.W.	10/18/2006	6/4/2010
SMT-1028-S-5V-R.idw		 pui audio a projects unlimited company		SMT-1028-S-5V-R Transducer (Electro-Mech)			Edition	Sheet
						-	1 / 1	